

# “What are we even talking about when we say “species tree’?”

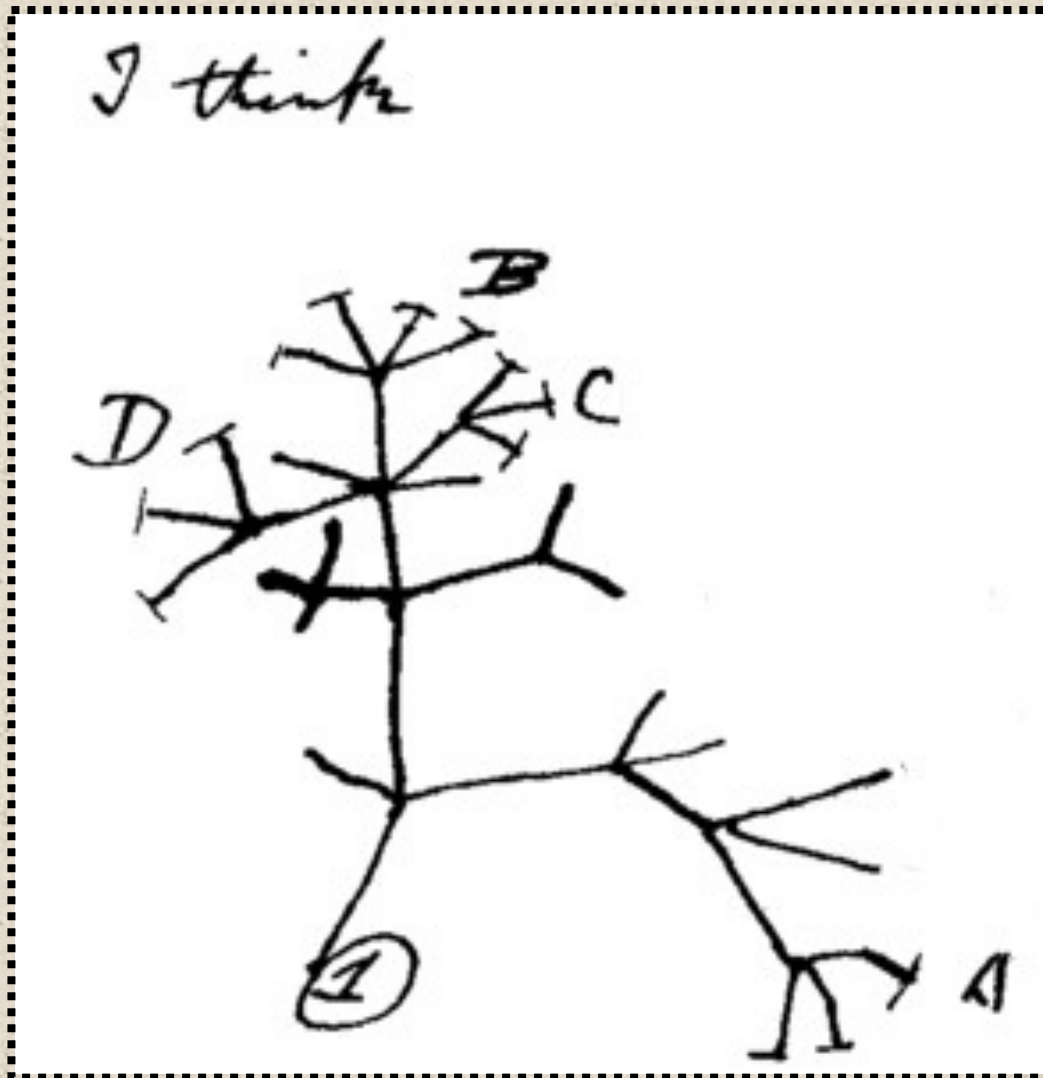

*Anne D. Yoder  
Department of Biology  
Duke University  
May 31, 2023*

# The one and only figure in Darwin's *Origin of Species*

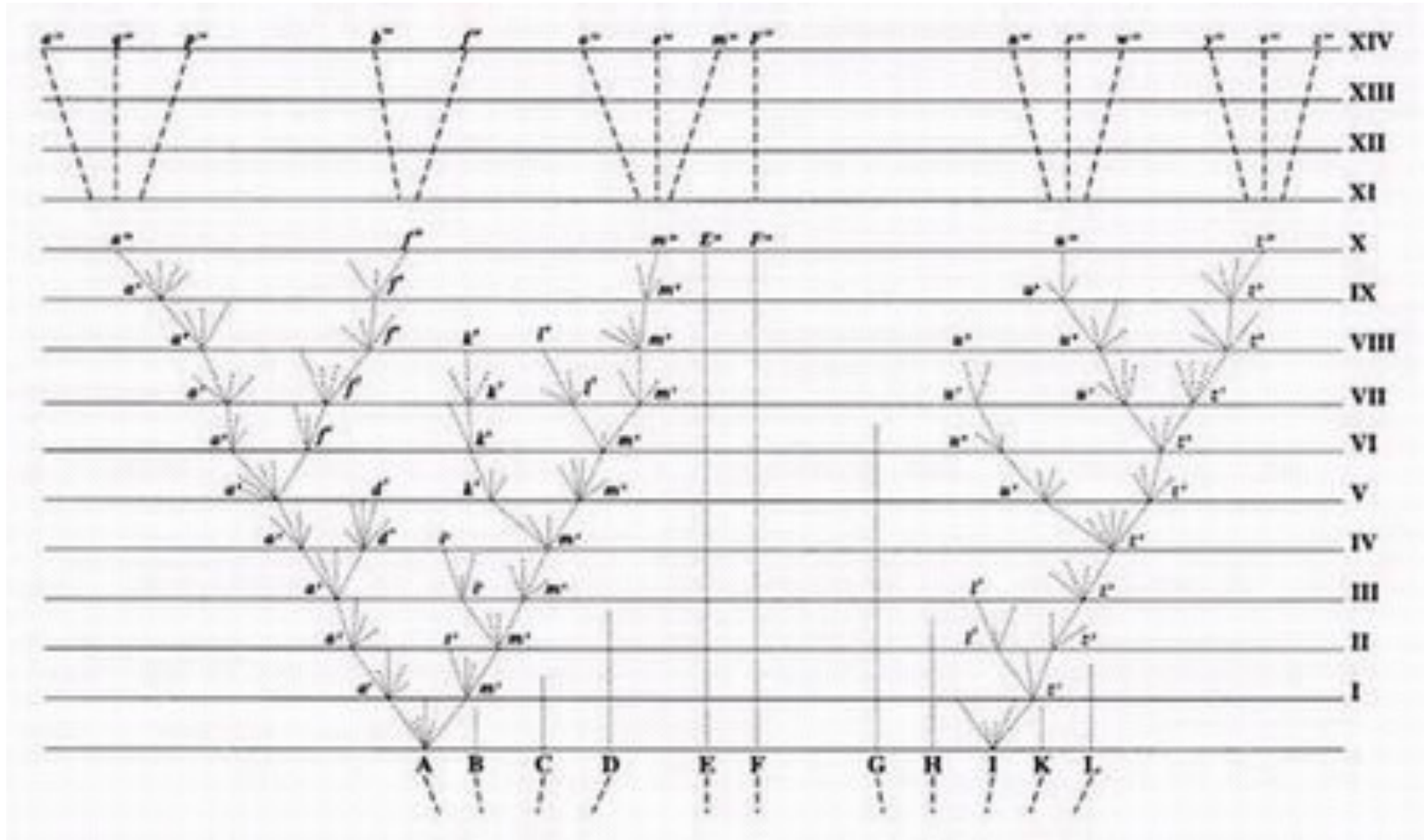

**Ancestor/Descendant Relationships Across Life on Earth**



Data SIO, NOAA, U.S. Navy, NGA, GEBCO  
Image Landsat

Google earth

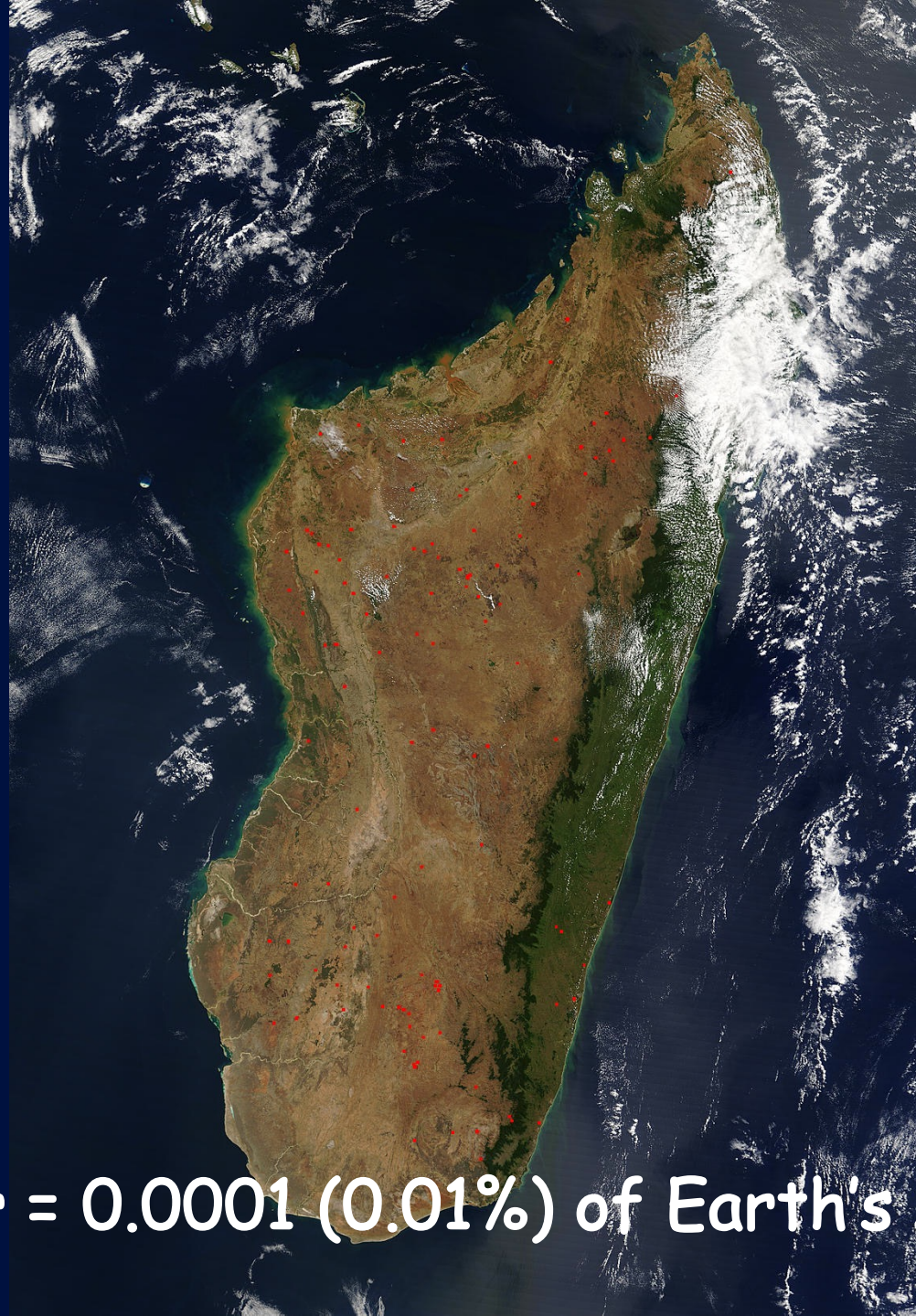

Madagascar = 0.0001 (0.01%) of Earth's surface



May 3, 2005

vol. 102 no. suppl 1

PNAS



Almost 20% of  
primate species  
diversity is found on  
an island roughly the  
size of California



**IUCN has declared lemurs to be the most threatened mammals on earth**



A photograph of two brown lemurs with large, striking blue eyes clinging to a tree branch. The lemurs are looking directly at the camera with a curious expression. The background is a soft-focus green and yellow, suggesting a forest environment. The text "Species, populations, and their genomes are vanishing ..." is overlaid in yellow on the image. There are also blue arrow icons on the left and right sides of the image.

Species, populations, and their genomes are vanishing ...



THE OCEAN AGENCY/XYL/LOTLIN SEAN/VIEW SURVEY

But the excitement around cancer immunotherapies — two researchers won a Nobel prize last year for pioneering them — has been tempered after several participants in US clinical trials died from side effects. Regulators around the world have moved slowly to approve the treatments for sale. The US Food and Drug Administration has approved only three cancer immunotherapies so far, and the Chinese drug regulator has approved none.

Before 2016, Chinese regulations for the sale of cell therapies were ambiguous, and many hospitals sold the treatments to patients while safety and efficacy testing was still under way. Ren Jun, an oncologist at the Beijing Shijitan Hospital Cancer Center, estimates that roughly one million people paid for such procedures.

But the market came under scrutiny when it was revealed that a university student with a rare cancer had paid more than 200,000 yuan (US\$30,000) for an experimental immunotherapy, after seeing it promoted by a hospital on the Internet. The treatment was unsuccessful, and the student later died. The government cracked down on hospitals selling cell therapies — although clinical trials in which participants do not pay for treatment were allowed to continue.

#### GATHERING EVIDENCE

Under the proposed regulations, roughly 1,400 elite hospitals that conduct medical research, known as Grade 3A hospitals, would be able to apply for a licence to sell cell therapies, after proving that they have expertise in processing the cells and running clinical trials.

Once the hospital was licensed, its review board would oversee clinical research of experimental therapies, with participants who did not pay. If the board were to decide that these investigations had produced enough evidence that a therapy was safe and effective, the hospital would be able to start selling it.

Ren is confident that the measures would prevent treatments of unknown quality being promoted and sold.

But not everyone agrees. “The proposed regulation is a bad idea,” says Michele Teng, who studies cancer immunotherapy at QIMR Berghofer. “It is critical that any new cellular therapy to be administered into patients demonstrates its safety and efficacy in phase III efficacy trials.”

Having large, well-funded facilities and trained medical staff is not an adequate substitute for well-designed studies to determine whether a treatment is efficacious or not, says Douglas Sipp, who studies cell-therapy policies at the RIKEN Center for Biosystems Dynamics Research in Kobe, Japan.

The rules could even dissuade companies from doing rigorous studies, he says. ■



Habitats such as coral reefs have been hit hard by pollution and climate change.

#### BIODIVERSITY

## One million species face extinction

*Landmark United Nations report finds that human activities threaten ecosystems around the world.*

BY JEFF TOLLEFSON

Up to one million plant and animal species face extinction, many within decades, because of human activities, says the most comprehensive report yet on the state of global ecosystems.

The rate of species extinctions is already tens to hundreds of times higher than the average across the past ten million years. Without drastic action to conserve habitats, the extinction rate will only increase, says a United Nations-backed panel called the Intergovernmental Science-Policy Platform on Biodiversity and Ecosystem Services (IPBES).

About 75% of land and 66% of ocean areas have been “significantly altered” by people, driven in large part by agriculture, according to a summary of the work, released on 6 May (see [go.nature.com/2v4zbn9](https://go.nature.com/2v4zbn9)). The loss of species and habitats poses as much a danger to life on Earth as climate change does, the IPBES report says.

The analysis distils findings from nearly 15,000 studies and government reports, integrating information from the natural and social sciences, Indigenous peoples and traditional agricultural communities. The report is the first major international appraisal of biodiversity since 2005. Representatives of 132 governments met last week

in Paris to finalize and approve it.

“We have never had a single unified statement from the world’s governments that unambiguously makes clear the crisis we are facing for life on Earth,” says Thomas Brooks, chief scientist at the International Union for Conservation of Nature in Gland, Switzerland, who helped to edit the report. “That is really the absolutely key novelty that we see here.”

Without “transformative changes” to the world’s economic, social and political systems to address this crisis, the IPBES panel projects that major biodiversity losses will continue to 2050 and beyond.

The analysis, which will be released in full later this year, also inextricably links biodiversity loss and climate change. An estimated 5% of all species would be threatened with extinction by 2 °C of warming above pre-industrial levels — a threshold that the world could breach in the next few decades, unless greenhouse-gas emissions are drastically reduced.

The biodiversity crisis should be at the top of the global agenda alongside climate, said Anne Larigauderie, IPBES executive secretary, at a 6 May press conference in Paris. “We can no longer say that we did not know,” she said.

Brooks says that the IPBES report will help to set the agenda when governments negotiate conservation goals for the next decade at the UN Convention on Biodiversity next year. ■

Sinemurian [200.00 Ma]

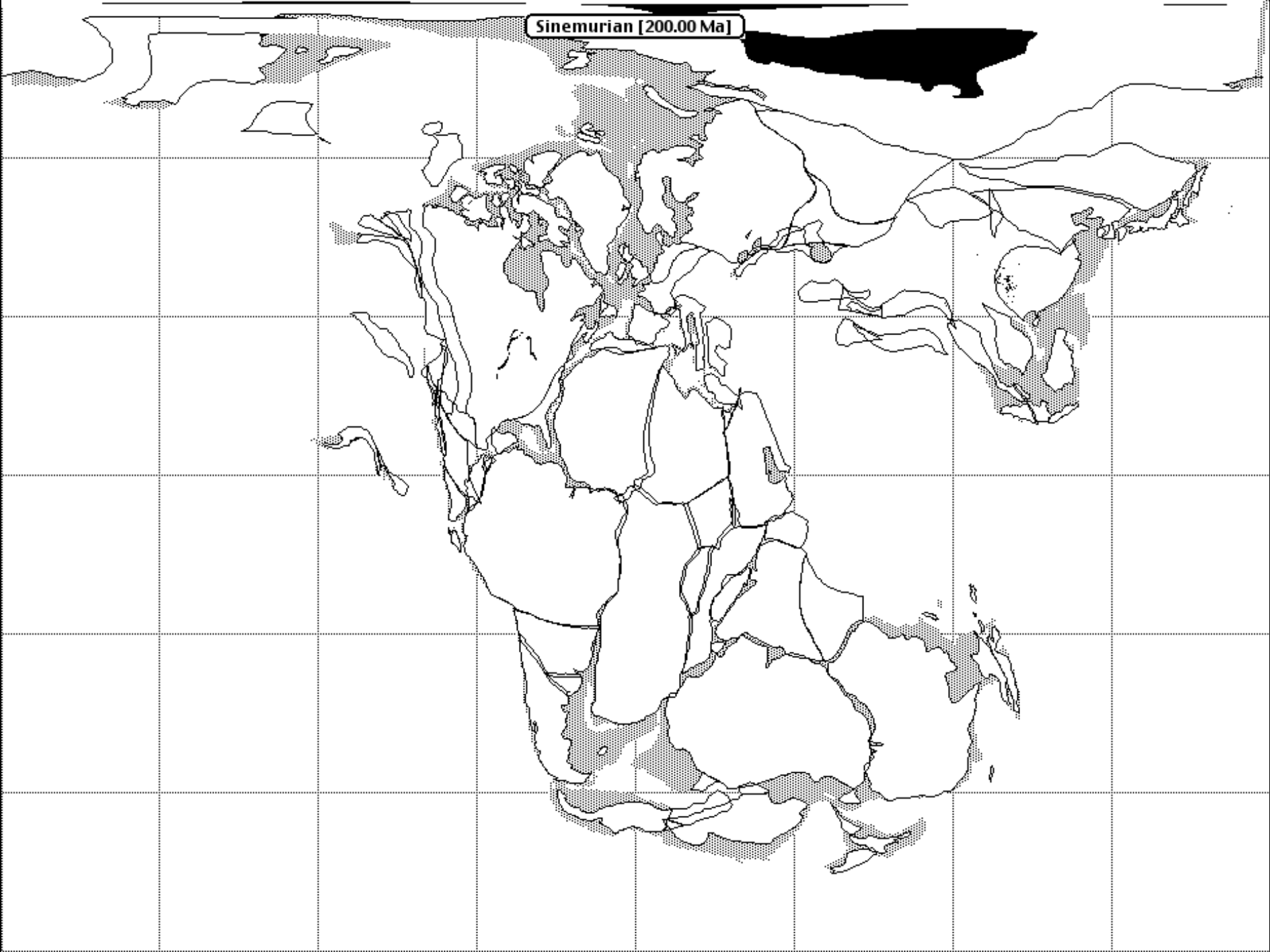



Speciation  
Laboratory



ENVIRONMENTAL HETEROGENEITY!



**Q1: How did they get there?**

## Ancient single origin for Malagasy primates

(primate origins/cytochrome *b*/molecular evolution)

ANNE D. YODER\*†‡, MATT CARTMILL§, MARYELLEN RUVOLO\*, KATHLEEN SMITH§, AND RYTAS VILGALYS¶

Departments of \*Anthropology and †Organismic and Evolutionary Biology, Harvard University, Cambridge, MA 02138;

§Department of Biological Anthropology and Anatomy, Duke University Medical School, Durham, NC 27710; and ¶Department of Botany, Duke University, Durham, NC 27708

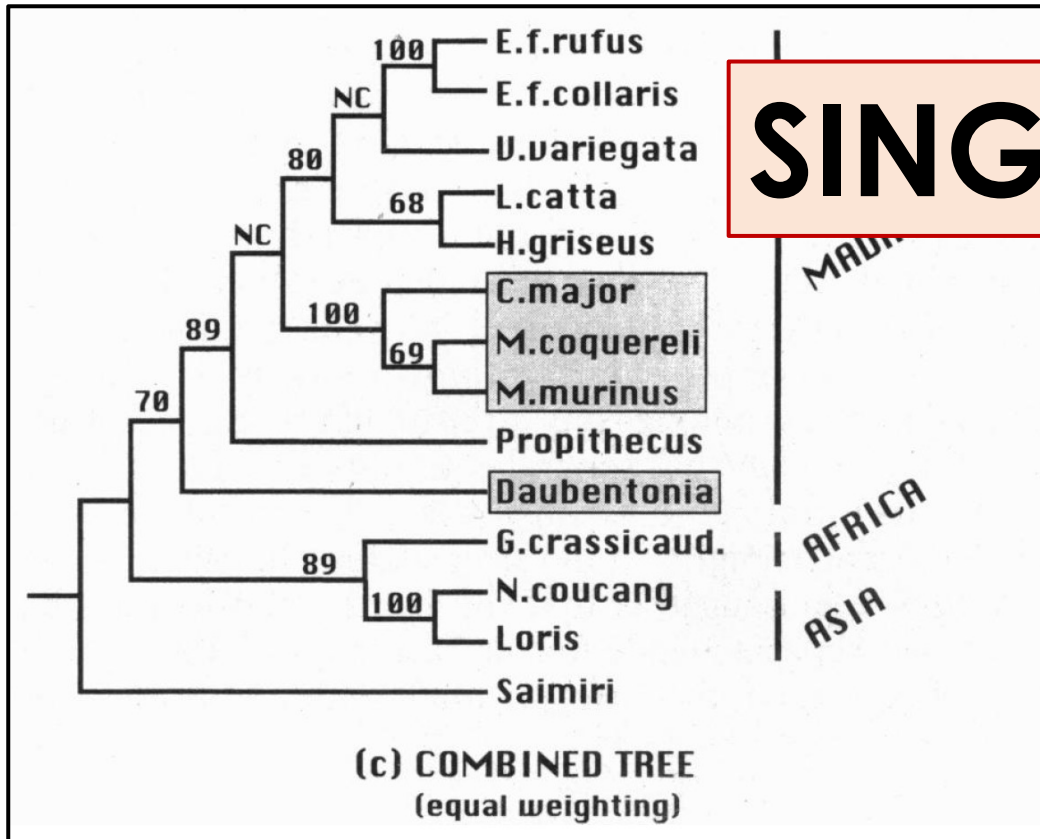

**SINGLE ORIGIN**

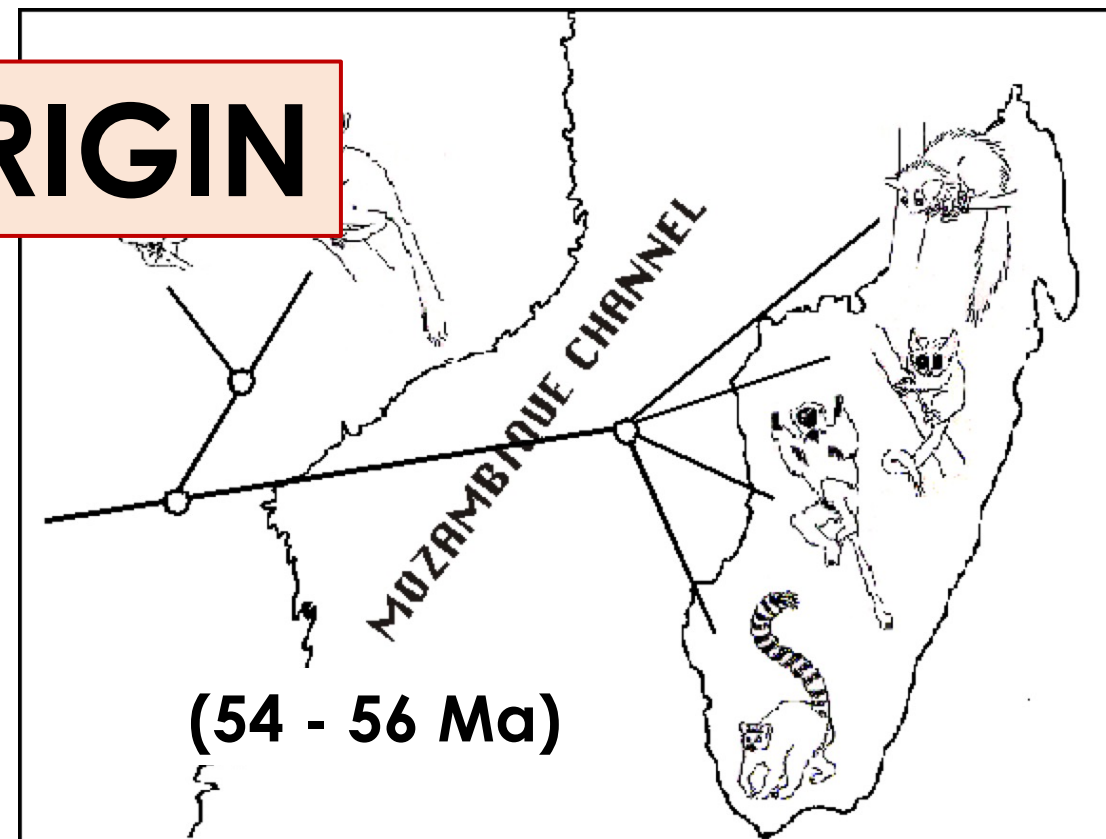

**Single origin of Malagasy Carnivora from an African ancestor**

Anne D. Yoder<sup>\*†</sup>, Melissa M. Burns<sup>†</sup>, Sarah Zehr<sup>‡</sup>, Thomas Delefosse<sup>\*</sup>, Geraldine Veron<sup>§</sup>, Steven M. Goodman<sup>†||</sup> & John J. Flynn<sup>‡</sup>

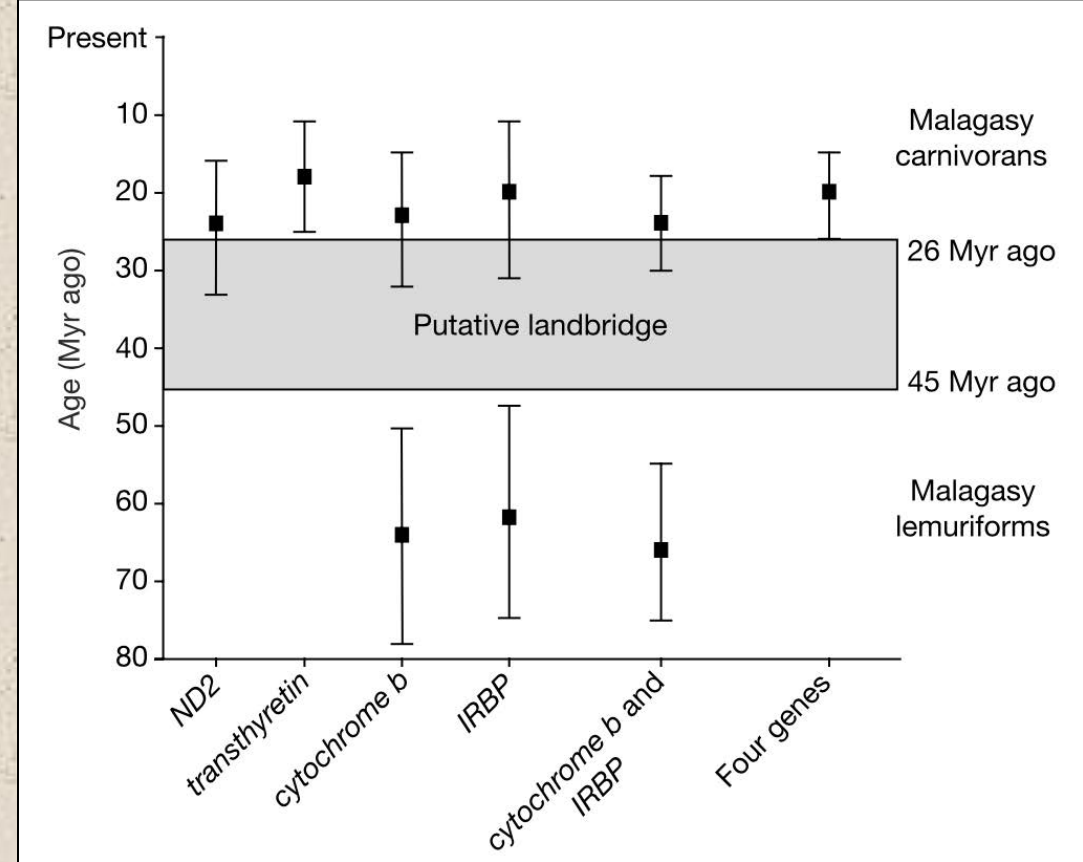
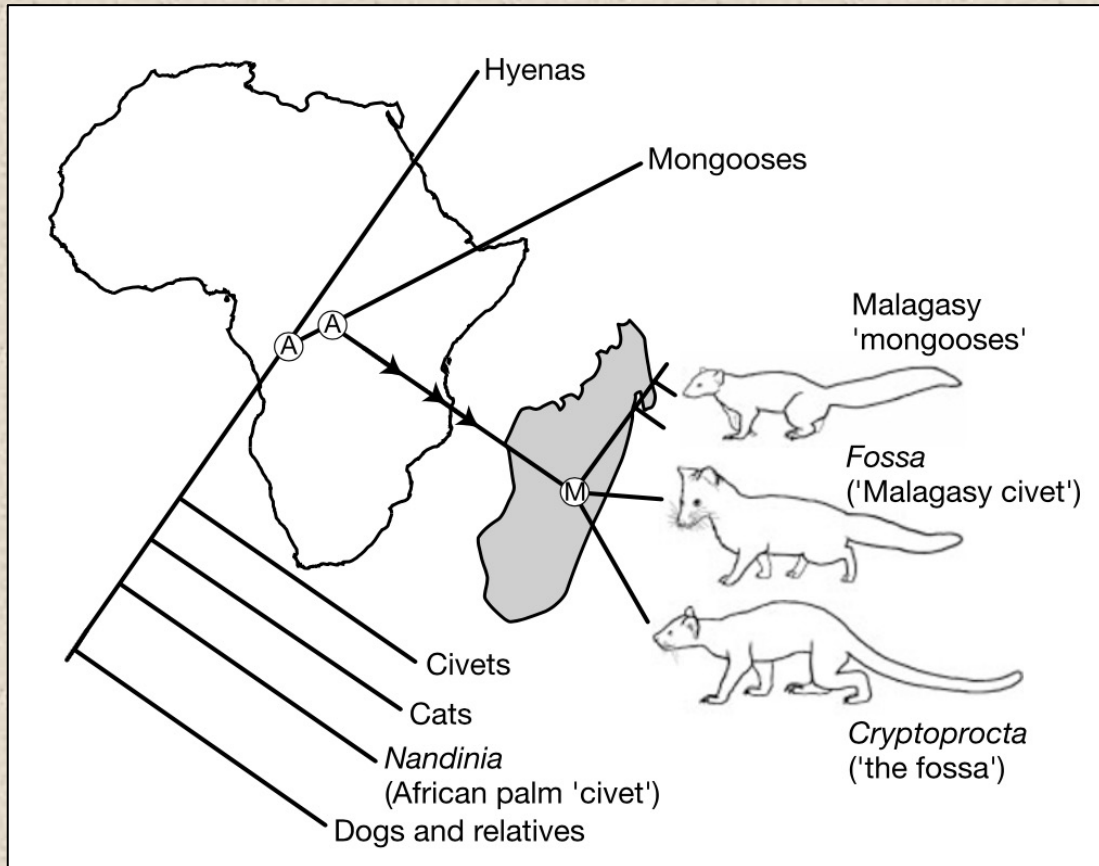

Shout out to Jeff Thorne and MultiDivTime!!!!



0°

30°

60 - 55 mya

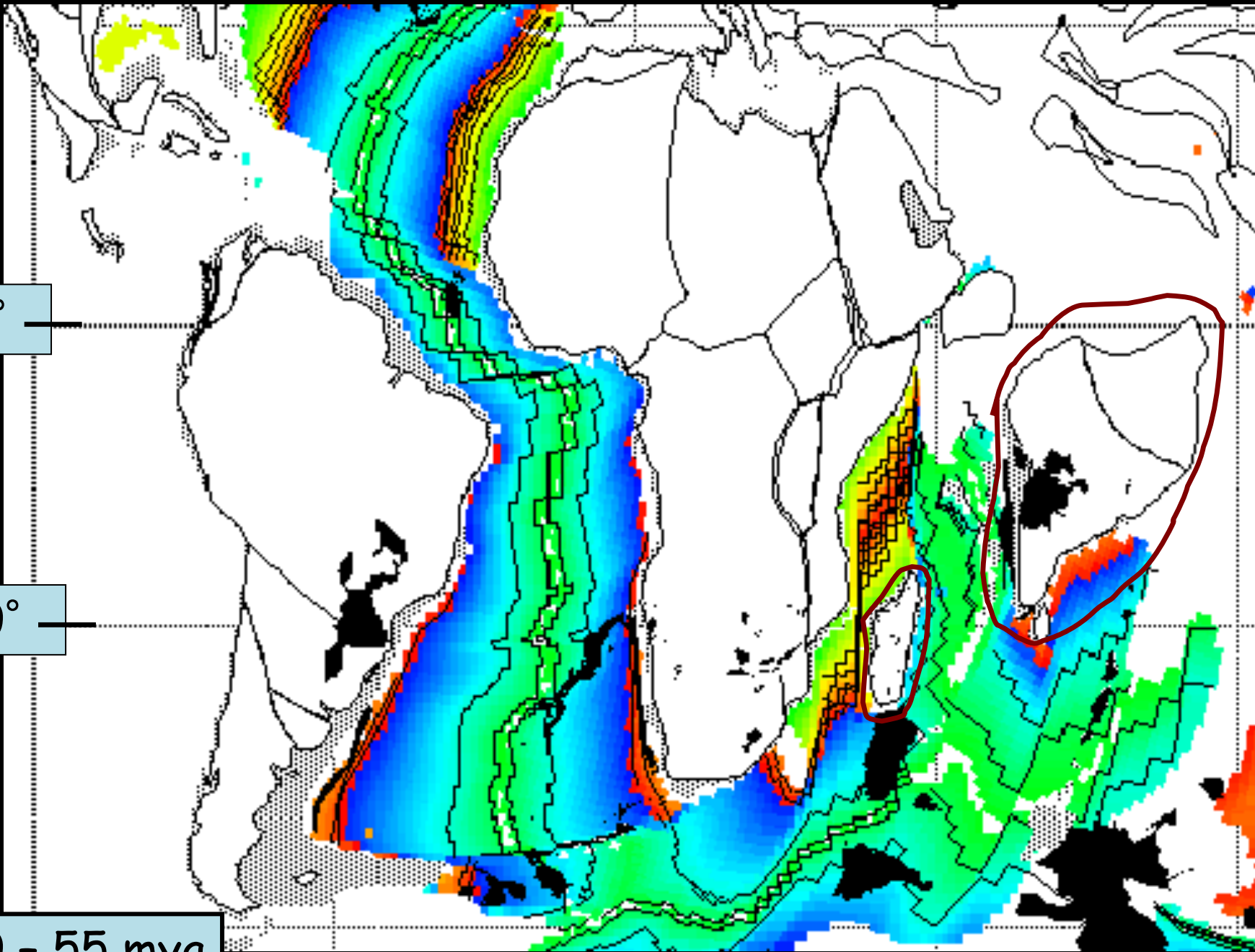







ILLUSTRATION BY STEPHEN D. NASH

**Fig. 2.2: An ancestral lemur makes its way across to Madagascar.**

# SCIENTIFIC REPORTS



**OPEN**

## **Snoozing through the storm: torpor use during a natural disaster**

Received: 24 February 2015

Accepted: 14 May 2015

**Julia Nowack, A. Daniella Rojas, Gerhard Körtner & Fritz Geiser**



SCIENTIFIC  
REPORTS



## Underground hibernation in a primate

Marina B. Blanco<sup>1,2</sup>, Kathrin H. Dausmann<sup>2</sup>, Jean F. Ranaivoarisoa<sup>3</sup> & Anne D. Yoder<sup>1,4</sup>



*Biol. Rev.* (2023), pp. 000–000.  
doi: 10.1111/brv.12966

1

# The colonisation of Madagascar by land-bound vertebrates

Jason R. Ali<sup>1,\*</sup>  and S. Blair Hedges<sup>2</sup>

<sup>1</sup>*Department of Earth Sciences, University of Hong Kong, Pokfulam Road, Hong Kong, China*

<sup>2</sup>*Center for Biodiversity, Temple University, 1925 N 12th Street, Suite 502, Philadelphia, PA 19122, USA*

ABSTRACT

2023

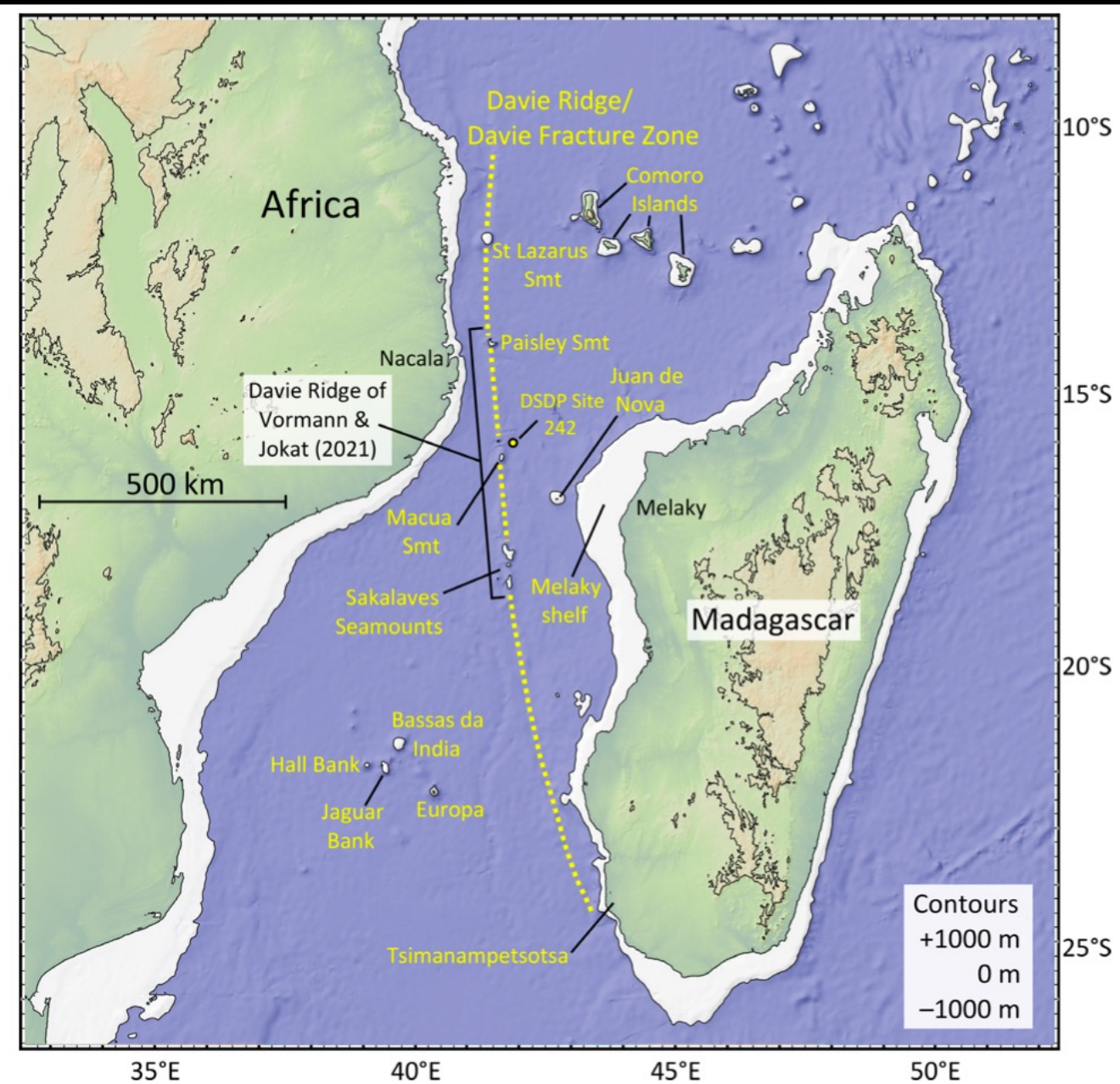

**Fig. 1.** Map of the Madagascar–SW Indian Ocean region showing key physiographical features. The base image was generated using *GeoMapApp* (Ryan *et al.*, 2009). The shaded contour intervals have 1000-m spacings: dark blue is  $-1000$  m and below, white is  $-1000$  to  $0$  m, pale green is  $0$  to  $+1000$  m, and khaki is  $+1000$  m and above. Note the Davie Ridge continental sliver of Vormann & Jokat (2021; see Figs 3 and 4), while the border between Mozambique and Tanzania meets the coast at *c.*  $10.5^{\circ}$  S. DSDP, Deep Sea Drilling Project; Smt, Seamount.

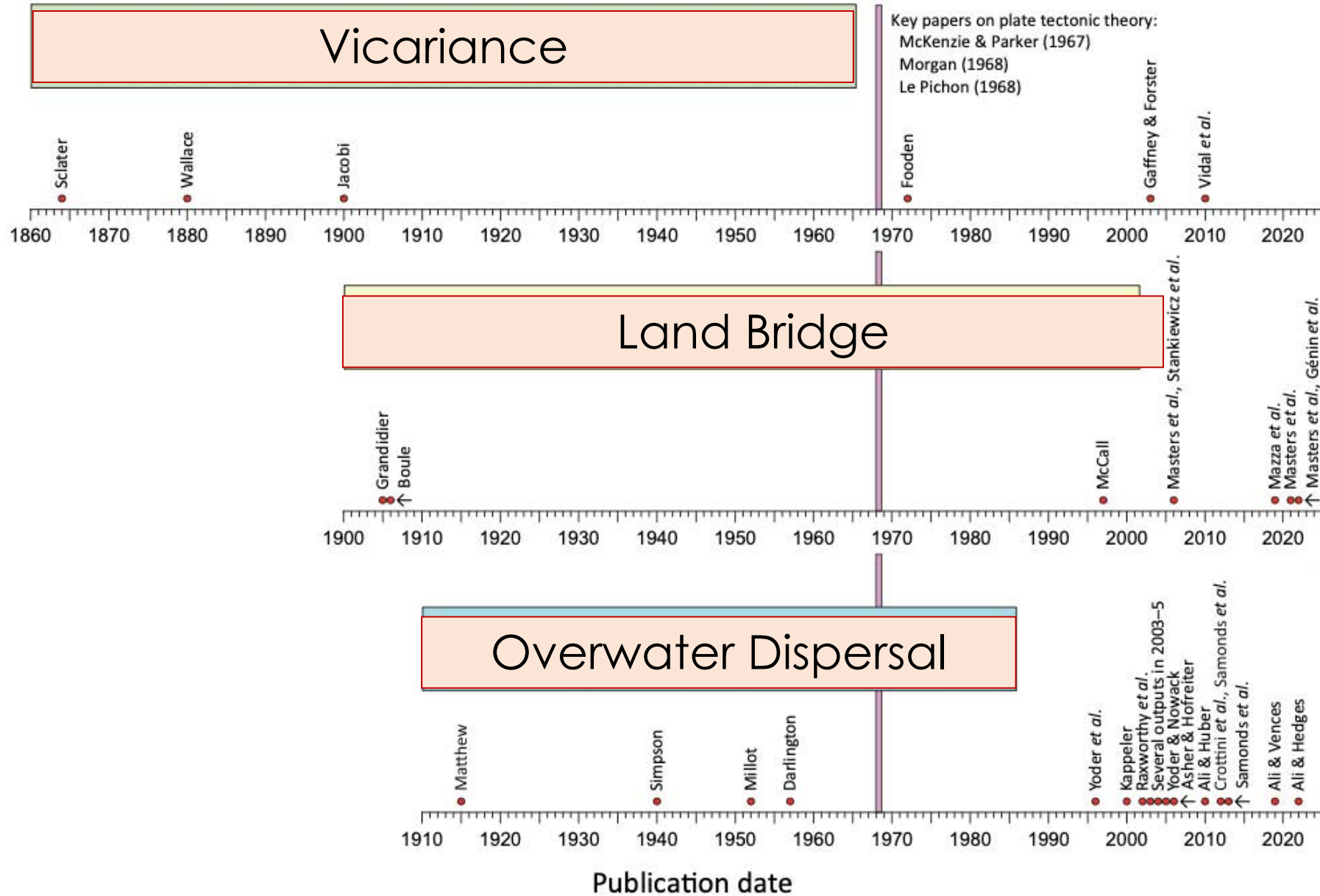

# Predicted pattern of “arrivals” under island-hopping/land-bridge model





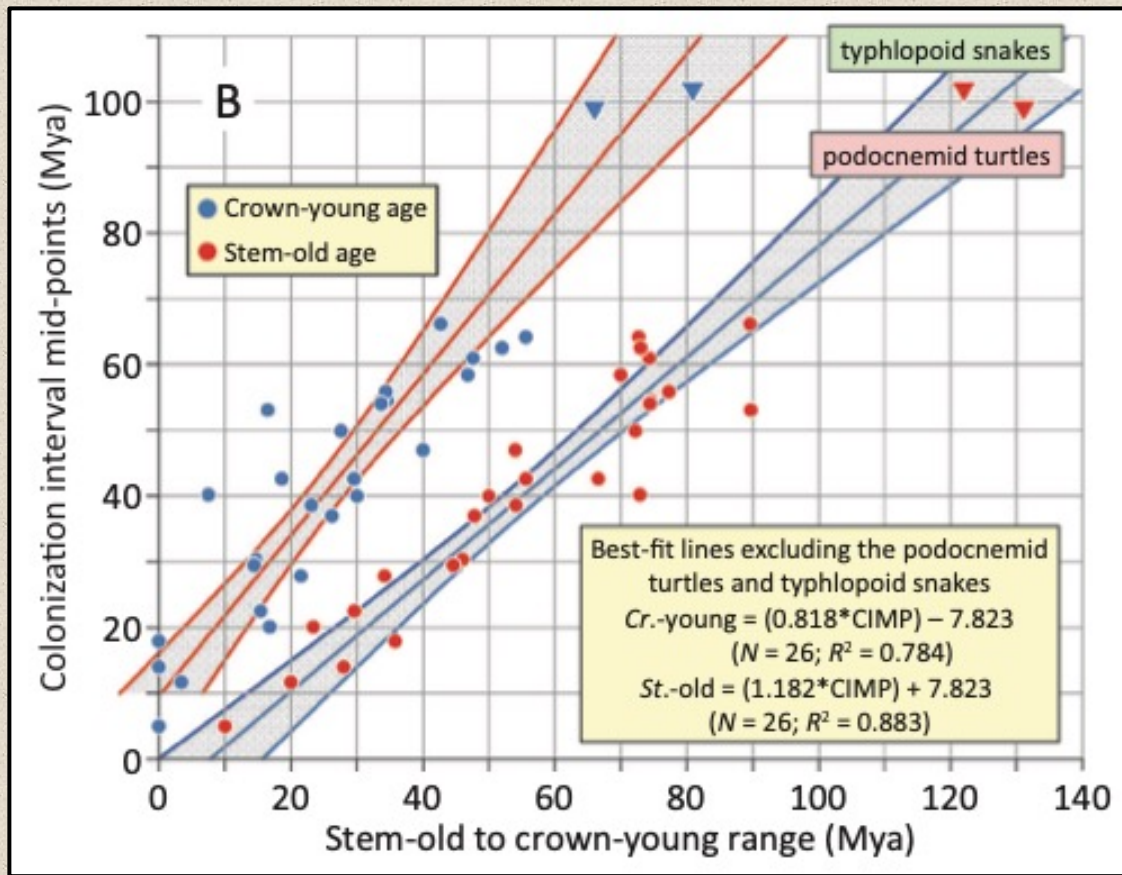

[Ali & Huber, 2023] show “that **stochastic over-water dispersal through time best explains the observed profile**, rather than passage along temporary causeways. This finding is congruent with the geological evidence that rejects the suggestion that Africa and Madagascar were connected by land bridges/stepping-stone chains in the Cenozoic.”

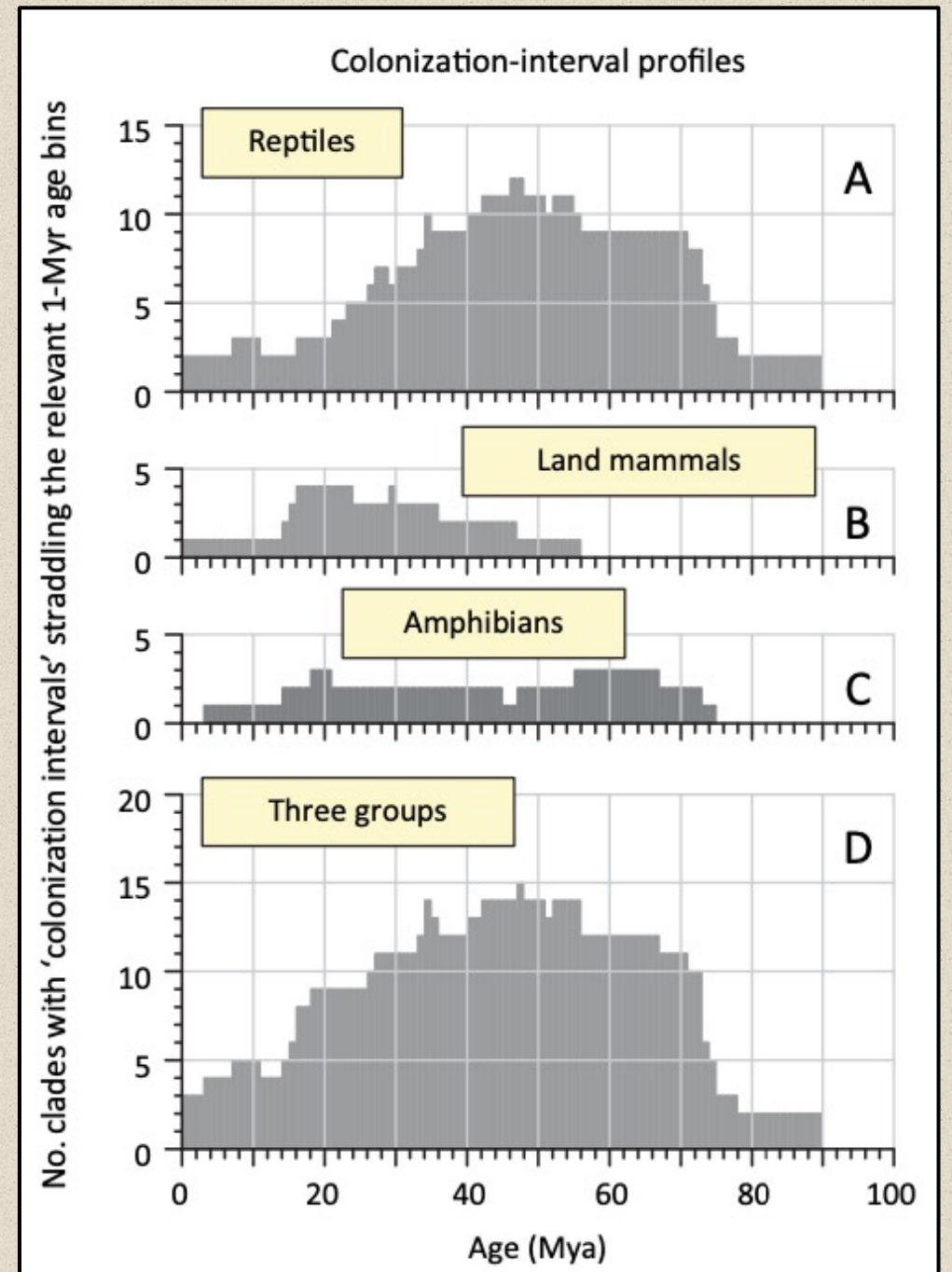

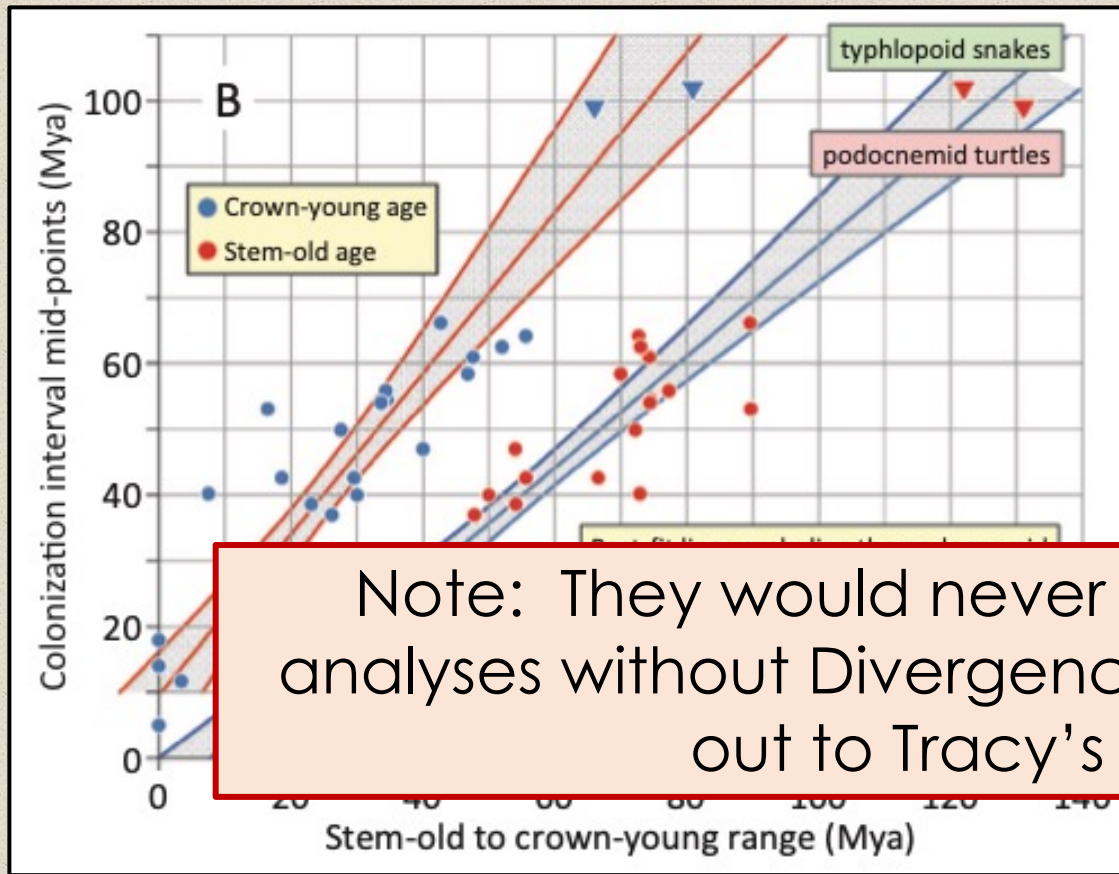

Note: They would never have been able to do these analyses without Divergence Time Estimation (with a shout out to Tracy's lecture Monday!)

[Ali & Huber, 2023] show “that **stochastic over-water dispersal through time best explains the observed profile**, rather than passage along temporary causeways. This finding is congruent with the geological evidence that rejects the suggestion that Africa and Madagascar were connected by land bridges/stepping-stone chains in the Cenozoic.”

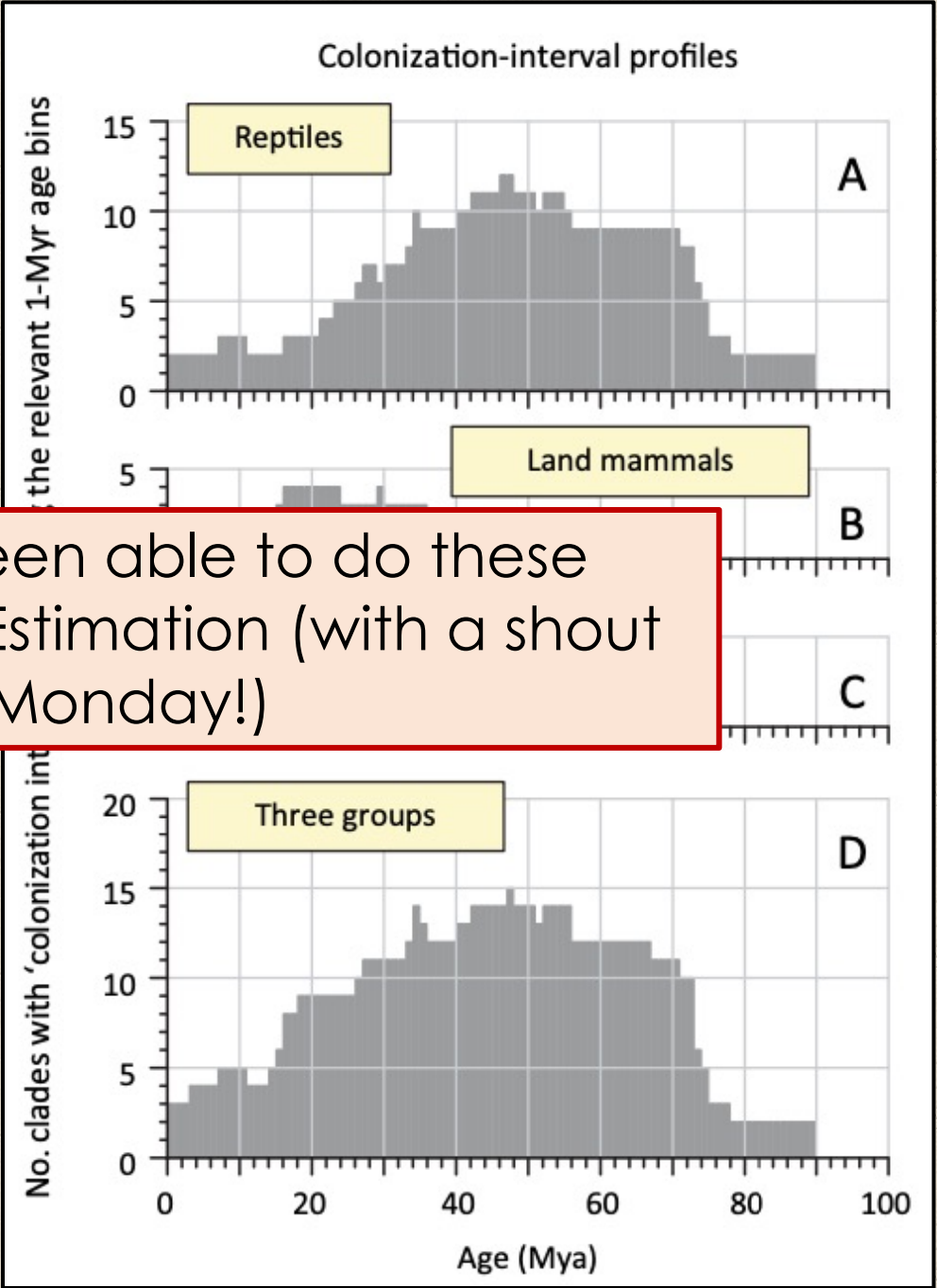

**Q2: When did they get there?**

*Syst. Biol.* 67(4):594–615, 2018

© The Author(s) 2018. Published by Oxford University Press, on behalf of the Society of Systematic Biologists.

This is an Open Access article distributed under the terms of the Creative Commons Attribution License (<http://creativecommons.org/licenses/by/4.0/>), which permits unrestricted reuse, distribution, and reproduction in any medium, provided the original work is properly cited. For Permissions, please email: [journals.permissions@oup.com](mailto:journals.permissions@oup.com)

DOI:10.1093/sysbio/syy001

Advance Access publication January 12, 2018

## Using Phylogenomic Data to Explore the Effects of Relaxed Clocks and Calibration Strategies on Divergence Time Estimation: Primates as a Test Case

MARIO DOS REIS<sup>1,2,\*</sup>, GREGG F. GUNNELL<sup>3,†</sup>, JOSE BARBA-MONTOYA<sup>2</sup>, ALEX WILKINS<sup>3,4</sup>, ZIHENG YANG<sup>2</sup>, AND ANNE D. YODER<sup>5</sup>

<sup>1</sup>*School of Biological and Chemical Sciences, Queen Mary University of London, Mile End Road, London E1 4NS, UK;*

<sup>2</sup>*Department of Genetics, Evolution and Environment, University College London, Gower Street, London WC1E 6BT, UK;*

<sup>3</sup>*Division of Fossil Primates, Duke University Lemur Center, Durham, 1013 Broad Street, NC 27705, USA;*

<sup>4</sup>*Department of Anthropology, The Ohio State University, Columbus, OH 43210, USA; and*

<sup>5</sup>*Department of Biology, Duke University, Durham, NC 27708, USA*

<sup>†</sup>*Deceased.*

*\*Correspondence to be sent to: School of Biological and Chemical Sciences, Queen Mary University of London, London E1 4NS, UK;*

*Email: [m.dosreisbarros@qmul.ac.uk](mailto:m.dosreisbarros@qmul.ac.uk).*

*Received 25 March 2017; reviews returned 26 December 2017; accepted 5 January 2018*

*Associate Editor: Simon Ho*

**2018**

**CONCATENATION!!!!**

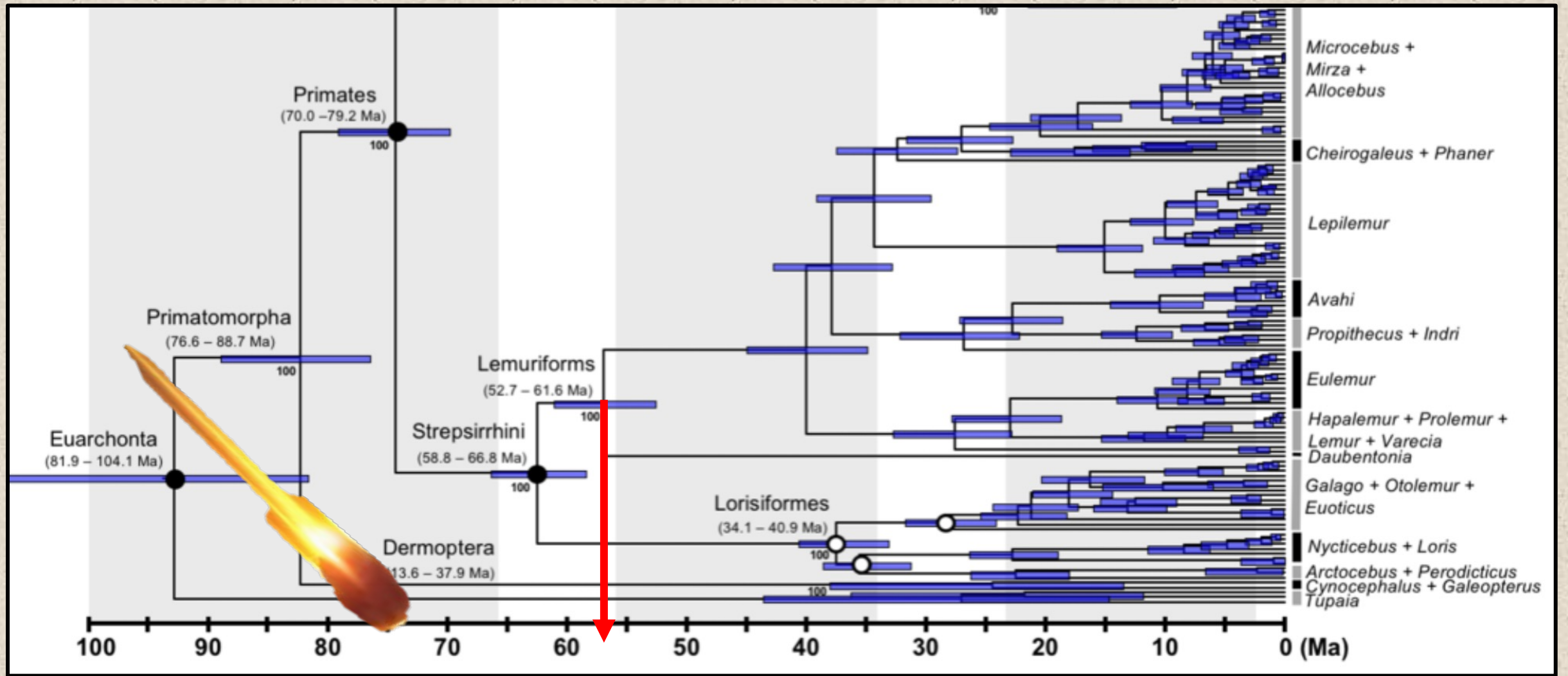

**No fossil record!!!**

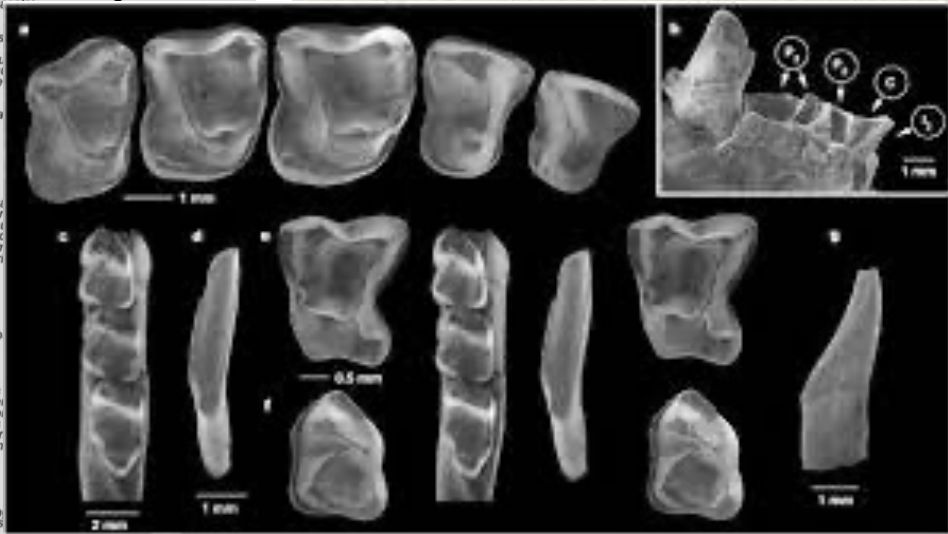
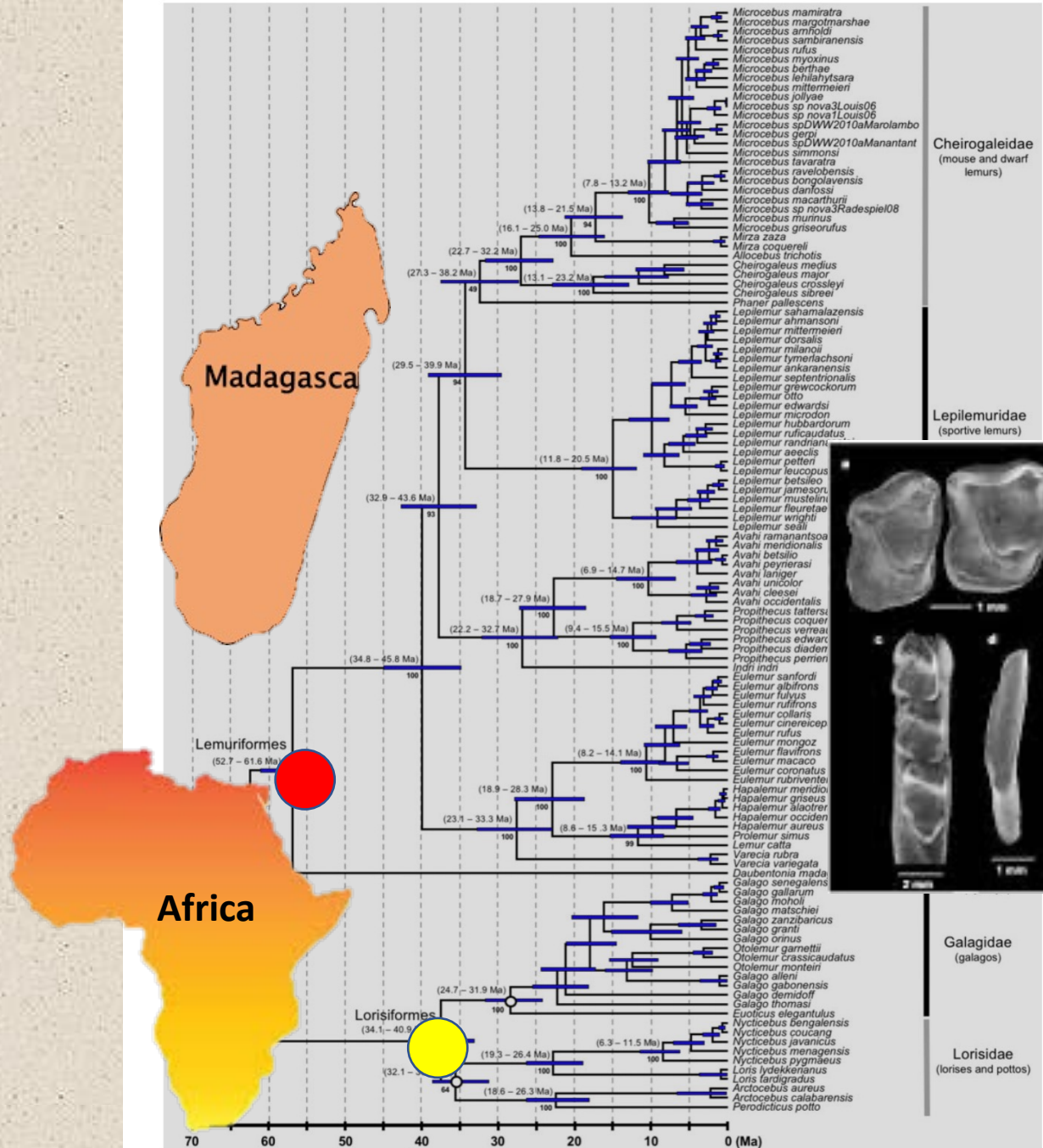

**Hold these thoughts ...**



# Approximately 90 percent of all plant and animal species found in Madagascar are endemic

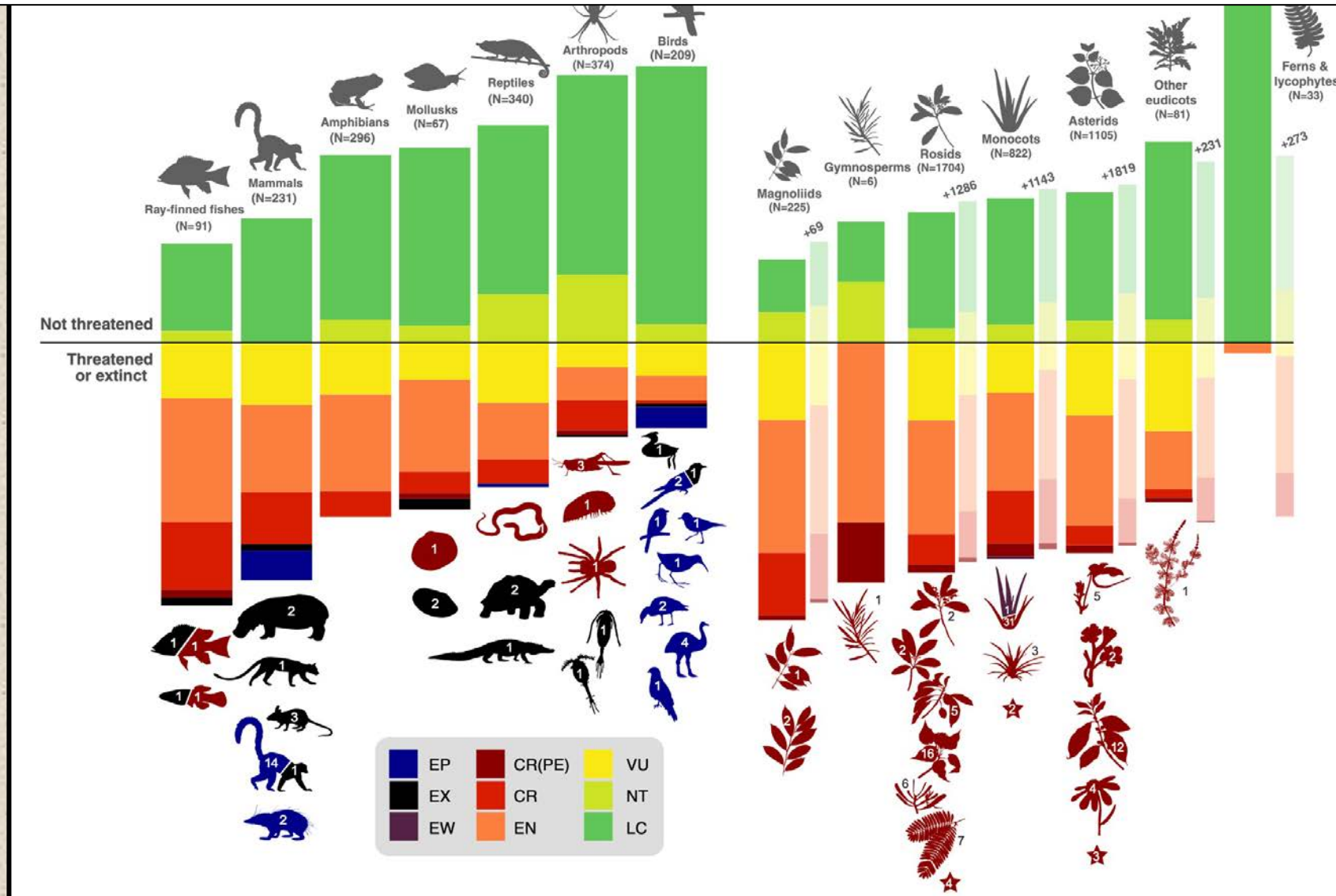

**Q3: What has generated all of  
this biological diversity?**

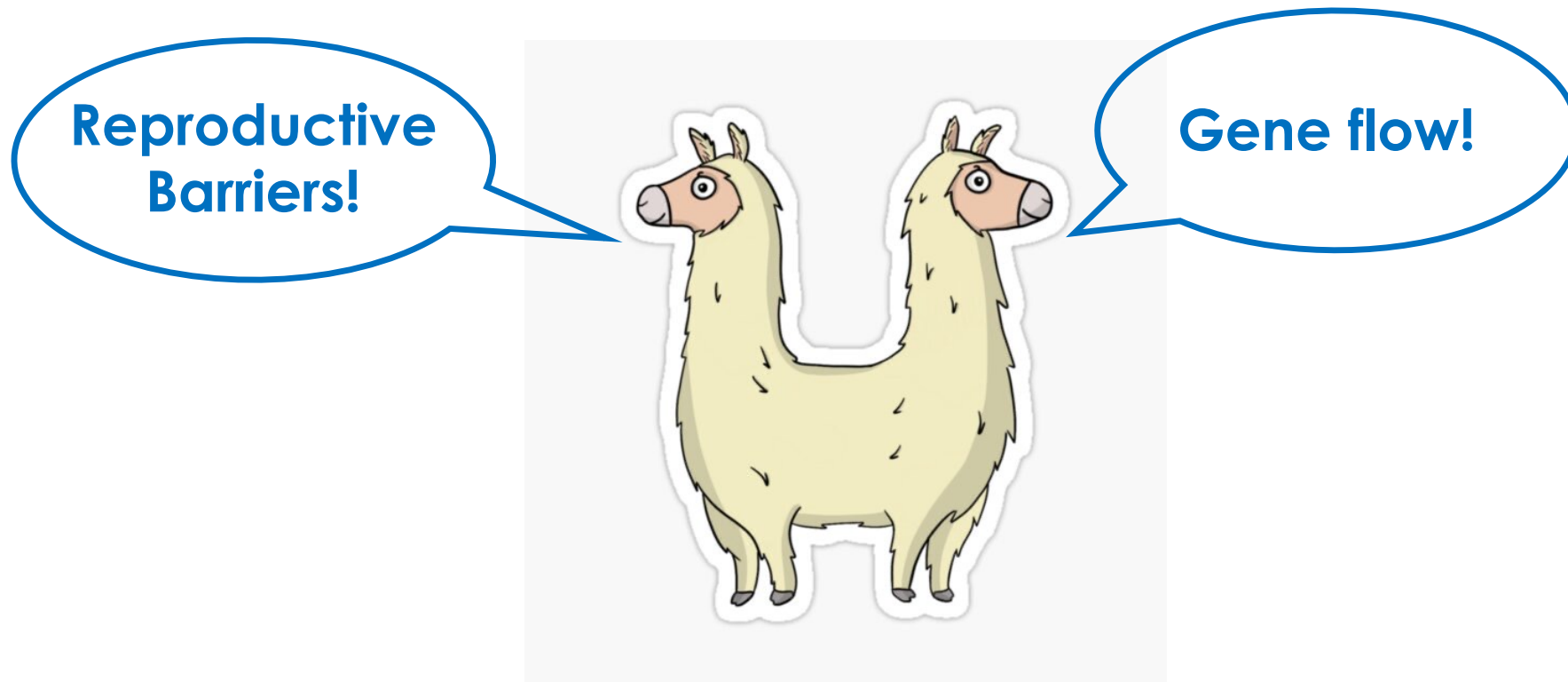

**Speciation is a “push me pull you”  
between reproductive barriers (of  
all kinds) and gene flow**

# We want to know things like:

## **Conservation concern:**

- How many species are out there and where do we find them?
- Are their populations growing, declining, holding steady?
- How does present-day demography relate to ancestral demography? (this is another way of saying the same thing)

## **Basic science:**

- When did species diverge from one another?
- Why and how did they diverge?
- What is maintaining species boundaries?
- Are they exchanging genes?
- And if so, is this a neutral (“speciation with gene flow”) or selection-driven (“adaptive introgression”) process?

**Why mouse lemurs???**

# MAKE WAY FOR THE MOUSE LEMUR

*If a US biochemist has his way, the world's tiniest primate could become a top research animal for genetics.*

BY LESLIE ROBERTS

**O**nja is struggling tonight — her hands keep slipping off a miniature grip bar used to measure her strength. “Come on, you can do better,” coos Zeph Pendleton, who is gently supporting the mouse lemur as she tries to get a firm hold. Finally, the animal gets her fingers around the bar and gives it a tug. It records a force of 1 kilogram, impressive for a creature weighing only 41 grams. “Good,” says Pendleton, a research assistant who is working here in the rainforest at Centre ValBio, a research station at Ranomafana National Park in Madagascar.

RIJASOLO/RMA PRESS

# **My Addiction Story**



**Joerg Ganzhorn**



**Steve Goodman**

January 27, 1997

Dear Anne,

For the past year or two Rodin, a student that works closely with Joerg Ganzhorn, has been collecting *Microcebus* in western Madagascar for a morphological study. He has done very well and **the specimens seem to include four or five types (myoxinus, murinus, a rufous murinus type that is not myoxinus [too big], and two that are probably undescribed)**. He has religiously collected tissues ... [more details]

Cheers for now,  
Steve

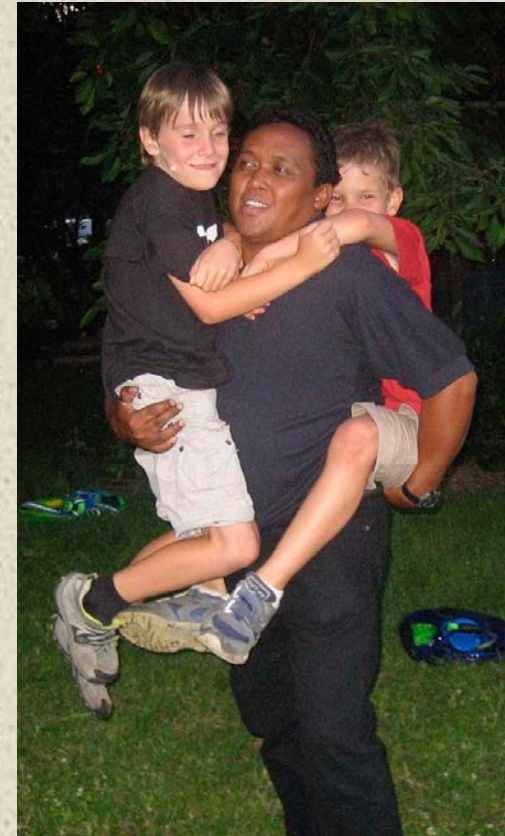

**Rodin Rasoloarison**



## 1973 – 1993: two species taxonomy

*Microcebus murinus* (grey mouse lemur); dry deciduous habitat; distributed throughout the west.

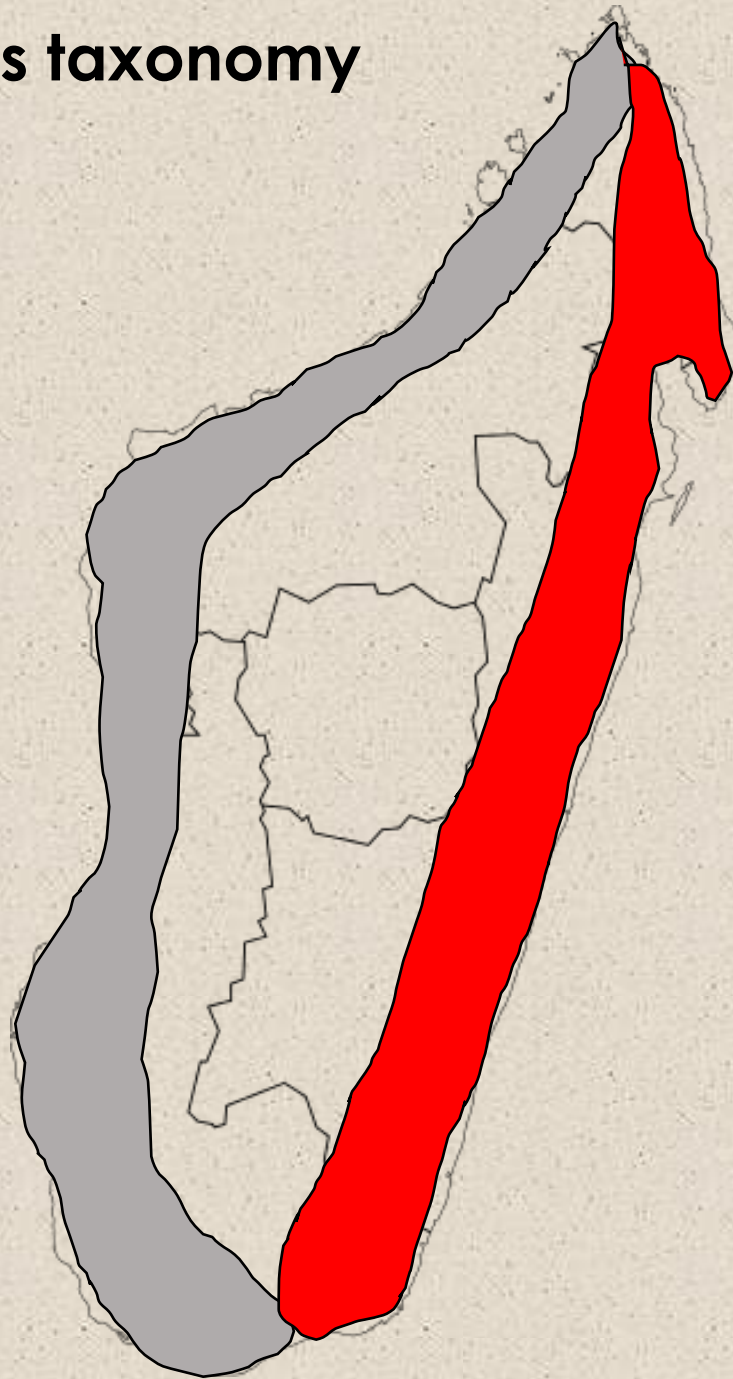

*Microcebus rufus* (roufus mouse lemur); wet forest habitat; distributed throughout the east.

# 1999: D-loop sequences – barely alignable!

D-loopGDE.nxs

Project of "D-l... Character Matrix

Matrix Alter Select Display Analysis:Matrix Window Character Matrix

Taxon \ Character

Taxon	Character	42	43	43	43	43	43	44	44	44	44	44	44	44	45	45	45	45	45	45	46	46	46	46	46	46	47	47	47	47	47	47	48	48	48	48	48	48	49	49	49	49	49	49	50	50	50	50	50	50	50	50																												
11 #RMR111		g	t	a	c	a																				t	t	a	g	c	g	c	a	t	c	a	a	g	t	c	c	c	c	g	a	a	a	a	g	t	c	c	c	a	g	t	c	a	c	c	a	t	g	a	c	t														
12 #RMR110		g	t	a	c	a																				t	t	a	g	c	g	c	a	t	c	a	a	g	t	c	c	c	c	g	a	a	a	a	g	t	c	c	c	a	g	t	c	a	c	c	a	t	g	a	c	t														
13 #RMR106		g	t	a	c	a																				t	a	g	c	g	c	a	t	c	a	a	g	t	c	c	c	c	g	a	a	a	a	g	t	c	c	c	a	g	t	c	a	c	c	a	t	g	a	c	t															
14 #RMR123		g	t	a	c	a																				t	c	a	g	c	g	c	a	t	c	a	a	g	t	c	a	g	t	c	c	c	c	g	a	a	a	a	g	t	c	c	c	a	g	t	c	a	c	c	a	t	g	g	c	t										
15 #RMR119		g	t	a	c	a																				t	c	a	g	c	g	c	a	t	c	a	a	g	t	c	c	c	c	g	a	a	a	a	g	t	c	c	c	a	g	t	c	a	c	c	a	t	g	g	c	t														
16 #RMR115		g	t	a	c	a																				t	c	a	g	c	g	c	a	t	c	a	a	g	t	c	a	g	t	c	c	c	c	g	a	a	a	a	g	t	c	c	c	a	g	t	c	a	c	c	a	t	g	g	c	t										
17 #RMR128		g	t	a	c	a																				t	c	a	g	c	g	c	a	t	c	a	a	g	t	c	a	g	t	c	c	c	c	g	a	a	a	a	g	t	c	c	c	a	g	t	c	a	c	c	a	t	g	g	c	t										
18 #RMR122		g	t	a	c	a																				t	c	a	g	c	g	c	a	t	c	a	a	g	t	c	a	g	t	c	c	c	c	g	a	a	a	a	g	t	c	c	c	a	g	t	c	a	c	c	a	t	g	g	c	t										
19 #RMR124		g	t	a	c	a																				t	c	a	g	c	g	c	a	t	c	a	a	g	t	c	a	g	t	c	c	c	c	g	a	a	a	a	g	t	c	c	c	a	g	t	c	a	c	c	a	t	g	g	c	t										
20 #RMR118		g	t	a	c	a																				t	c	a	g	c	g	c	a	t	c	a	a	g	t	c	a	g	t	c	c	c	c	g	a	a	a	a	g	t	c	c	c	a	g	t	c	a	c	c	a	t	g	g	c	t										
21 #RMR116		g	t	a	c	a																				t	c	a	g	c	g	c	a	t	c	a	a	g	t	c	a	g	t	c	c	c	c	g	a	a	a	a	g	t	c	c	c	a	g	t	c	a	c	c	a	t	g	g	c	t										
22 #RMR130		g	t	a	c	a																				t	c	a	g	c	g	c	a	t	c	a	a	g	t	c	a	g	t	c	c	c	c	g	a	a	a	a	g	t	c	c	c	a	g	t	c	a	c	c	a	t	g	g	c	t										
23 #RMR127		g	t	a	c	a																				t	c	a	g	c	g	c	a	t	c	a	a	g	t	c	a	g	t	c	c	c	c	g	a	a	a	a	g	t	c	c	c	a	g	t	c	a	c	c	a	t	g	a	c	t										
24 #RMR117		g	t	a	c	a																				t	c	a	g	c	g	c	a	t	c	a	a	g	t	c	a	g	t	c	c	c	c	g	a	a	a	a	g	t	c	c	c	a	g	t	c	a	c	c	a	t	g	a	c	t										
25 #RMR125		g	t	a	c	a																				t	c	a	g	c	g	c	a	t	c	a	a	g	t	c	a	g	t	c	c	c	c	g	a	a	a	a	g	t	c	c	c	a	g	t	c	a	c	c	a	t	g	a	c	t										
26 #RMR126		g	t	a	c	a																				t	c	a	g	c	g	c	a	t	c	a	a	g	t	c	a	g	t	c	c	c	c	g	a	a	a	a	g	t	c	c	c	a	g	t	c	a	c	c	a	t	g	a	c	t										
27 #RMR121		g	t	a	c	a																				t	c	a	g	c	g	c	a	t	c	a	a	g	t	c	a	g	t	c	c	c	c	g	a	a	a	a	g	t	c	c	c	a	g	t	c	a	c	c	a	t	g	a	c	t										
28 #RMR129		g	t	a	c	a																				t	c	a	g	c	g	c	a	t	c	a	a	g	t	c	a	g	t	c	c	c	c	g	a	a	a	a	g	t	c	c	c	a	g	t	c	a	c	c	a	t	g	a	c	t										
29 #RMR120		g	t	a	c	a																				t	a	g	c	g	c	a	t	c	a	a	g	t	c	a	g	t	c	c	c	c	g	a	a	a	a	g	t	c	c	c	a	g	t	c	a	c	c	a	t	g	a	c	t											
30 #RMR145		g	t	a	c	a	t	a	g	t	a	c	a	t	t	c	a	t	a	a	t	a	t	g	a	t	c	g	t	a	c	a	t	a	g	c	g	c	a	t	t	a	a	g	t	c	c	c	c	g	a	a	a	a	g	t	c	c	c	a	g	t	c	a	c	c	a	t	g	a	c	t								
31 #RMR143		g	t	a	c	a	t	a	g	t	a	c	a	t	t	c	a	t	a	a	t	a	t	g	a	t	c	g	t	a	c	a	t	t	a	g	c	g	c	a	t	t	a	a	g	t	c	c	c	c	g	a	a	a	a	g	t	c	c	c	a	g	t	c	a	c	c	a	t	g	a	c	t							
32 #RMR144		g	t	a	c	a	t	a	g	t	a	c	a	t	t	c	a	t	a	a	t	a	t	g	a	t	c	g	t	a	c	a	t	t	a	g	c	g	c	a	t	t	a	a	g	t	c	c	c	c	g	a	a	a	a	g	t	c	c	c	a	g	t	c	a	c	c	a	t	g	a	c	t							
33 #RMR147		g	t	a	c	a	t	a	g	t	a	c	a	t	t	c	a	t	a	a	t	a	t	g	a	t	c	g	t	a	c	a	t	t	a	g	c	g	c	a	t	t	a	a	g	t	c	c	c	c	g	a	a	a	a	g	t	c	c	c	a	g	t	c	a	c	c	a	t	g	a	c	t							
34 #RMR142		g	t	a	c	a	t	a	g	t	a	c	a	t	t	c	a	t	a	a	c	a	t	g	a	t	c	g	t	a	c	a	t	t	a	g	c	g	c	a	t	t	a	a	g	t	c	c	c	c	g	a	a	a	a	g	t	c	c	c	a	g	t	c	a	c	c	a	t	g	a	c	t							
35 #RMR99		g	t	a	c	a	t	a	g	t	a	c	a	t	t	c	a	t	a	a	t	a	t	a	a	a	a	t	c	g	t	a	c	a	t	t	a	g	c	g	c	a	t	t	a	a	g	t	c	c	c	c	g	a	a	a	a	g	t	c	c	c	a	g	t	c	a	c	c	a	t	g	a	c	t					
36 #RMR95		g	t	a	c	a	t	a	g	t	a	c	a	t	t	c	a	t	a	a	t	a	t	a	a	a	a	t	c	g	t	a	c	a	t	t	a	g	c	g	c	a	t	t	a	a	g	t	c	c	c	c	g	a	a	a	a	g	t	c	c	c	a	g	t	c	a	c	c	a	t	g	a	c	t					
37 #RMR96		g	t	a	c	a	t	a	g	t	a	c	a	t	t	c	a	t	a	a	t	a	t	a	a	a	a	t	c	g	t	a	c	a	t	t	a	g	c	g	c	a	t	t	a	a	g	t	c	c	c	c	g	a	a	a	a	g	t	c	c	c	a	g	t	c	a	c	c	a	t	g	a	c	t					
38 #RMR97		g	t	a	c	a	t	a	g	t	a	c	a	t	t	c	a	t	a	a	t	a	t	a	a	a	a	t	c	g	t	a	c	a	t	t	a	g	c	g	c	a	t	t	a	a	g	t	c	c	c	c	g	a	a	a	a	g	t	c	c	c	a	g	t	c	a	c	c	a	t	g	a	c	t					
39 #RMR136		g	t	a	c	a	t	a	g	t	a	c	a	t	t	c	a	t	a	a	t	a	t	a	a	a	a	t	c	g	t	a	c	a	t	t	a	g	c	g	c	a	t	t	a	a	g	t	c	a	a	t	c	c	c	g	a	a	a	a	g	t	c	c	c	a	g	t	c	a	c	c	a	t	g	a	c	t		
40 #RMR138		g	t	a	c	a	t	a	g	t	a	c	a	t	t	c	a	t	a	a	t	a	t	a	a	a	a	t	c	g	t	a	c	a	t	t	a	g	c	g	c	a	t	t	a	a	g	t	c	c	c	c	g	a	a	a	a	g	t	c	c	c	a	g	t	c	a	c	c	a	t	g	a	c	t					
41 #RMR131		g	t	a	c	a	t	g	g	c	a	c	a	t	t	a	t	a	t	a	t	a	t	c	a	t	t	g	a	t	c	g	t	a	c	a	t	t	a	g	c	g	c	a	t	t	a	a	g	t	c	a	a	t	c	c	c	t	g	a	a	a	g	t	c	c	c	a	g	t	c	a	c	c	a	t	g	a	c	t
42 #RMR159		g	t	a	c	a	t	a	g	t	a	c	a	t	t	c	a	t	a	a	t	a	t	a	t	g	a	t	c	g	t	a	c	a	t	t	a	g	c	g	c	a	t	t	a	a	g	t	c	c	t	g	c	c	a	c	c	a	t	g	a	c	t																	
43 #RMR156		g	t	a	c	a	t	a	g																																																																							



*M. ravelobensis*



*M. murinus*



*M. griseorufus*

**Can *you* tell them apart???**



*M. tavaratra*



*M. berthae*



*M. rufus*

# Remarkable species diversity in Malagasy mouse lemurs (primates, *Microcebus*)

Anne D. Yoder\*<sup>†‡</sup>, Rodin M. Rasoloarison<sup>§</sup>, Steven M. Goodman<sup>†¶</sup>, Jodi A. Irwin\*<sup>||</sup>, Sylvia Atsalis\*, Matthew J. Ravosa\*<sup>†</sup>, and Jörg U. Ganzhorn\*\*

- Much more phylogenetic diversity than expected --- from two to eight species in just a few years

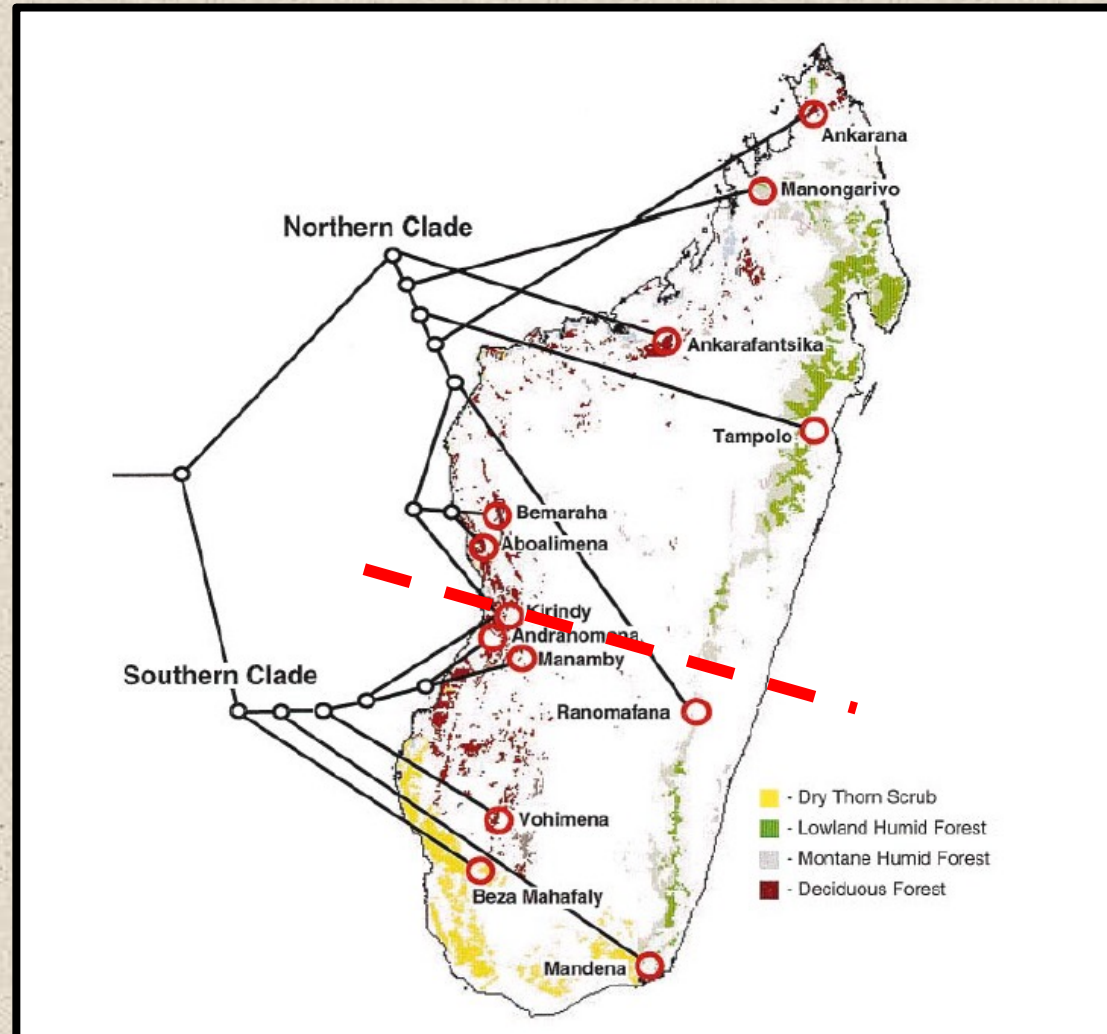

- Phylogeographic patterns don't fit previous east v. west assumptions

Yoder et al. (2000), *PNAS*

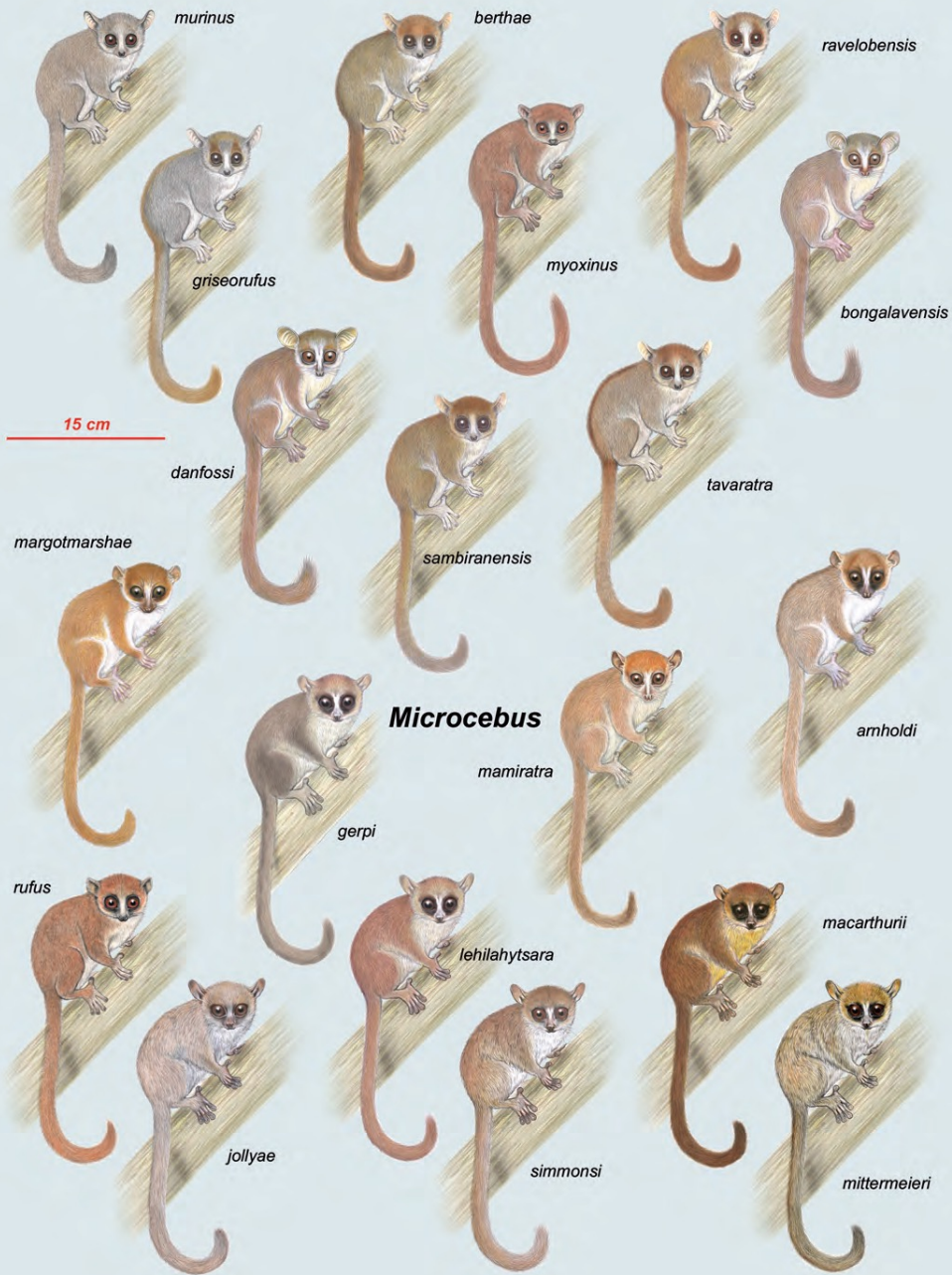

Recognized species diversity has gone from two species (1972 – 1993) to ~ 25 species (2023).

# Questions:

- Are these things actually different species?
- How can we even tell? (Especially when one is agnostic about species concepts?!!)
- What has driven lineage diversification?
- What is maintaining lineage diversification?  
Biology (i.e., RI)? Ecology? Both??
- If RI, is it prezygotic? Postzygotic? Both??

# The MSC Defined

Coalescent theory describes the genealogical histories of a sample of alleles from a population, with time running backwards from the present until the most recent common ancestor of the sample. The **Multispecies Coalescent (MSC)** is an extension of this process to multiple species.

# GENE TREES IN SPECIES TREES

WAYNE P. MADDISON

Department of Ecology and Evolutionary Biology, University of Arizona, Tucson, Arizona 85721, USA

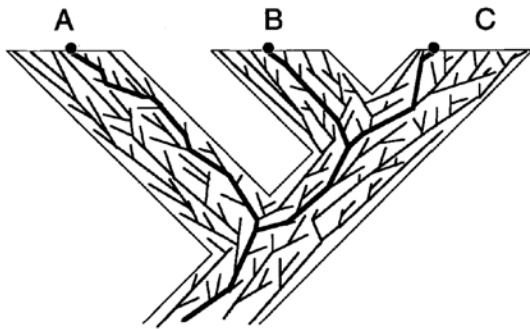

FIGURE 1. A gene tree contained within a species tree leading to three extant species: A, B, and C. Bold branches of gene tree show relationships among the sampled copies of the gene (●). Sampled copies from sister species B and C are sister copies.

A "species tree" can contain many "gene trees"

Gene trees often don't match the species tree

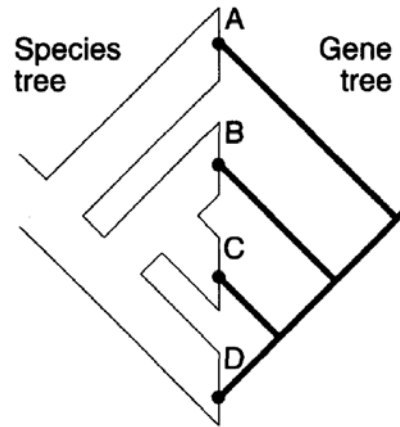
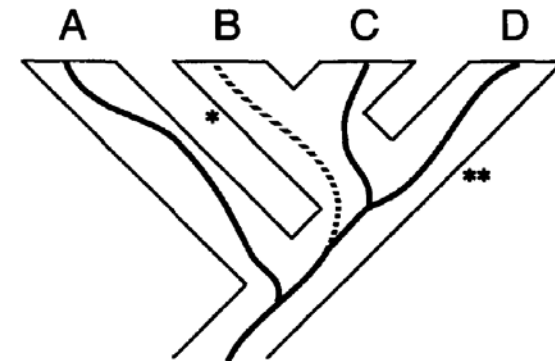

FIGURE 2. Discord between gene and species trees. At left is the species tree of four species, A, B, C, and D, and at right is the tree of a gene sampled one copy per species. Species B and C are sister species, but their gene copies are not sister copies.



Branch short and wide:  
Deep coalescence likely

Behavior of gene trees relates to MANY factors, including ancestral population sizes



AGCACTGACC**C**GCGGATGCTACGATCGACAT**C**GACGACACTAGCCGGGTACATCGATCACGCAT**T**GCGACT  
AGCACTGACC**C**GCGGATGCTACGATCGACAT**C**GACGACACTAGCCGGGT**T**CATCGATCACGCAT**T**GCGACT  
AGCACTGACC**C**GCGGATGCTACGATCGACAT**G**GACGACACTAGCCGGGTACATCGATCACGCAT**T**GCGACT  
AGCACTGACC**G**GCGGATGCTACGATCGACAT**C**GACGACACTAGCCGGGTACATCGATCACGCAT**T**GCGACT  
AGCACTGACC**C**GCGGATGCT**A**ACGATCGACAT**C**GACGACACTAGCCGGGTACATCGATCACGCAT**T**GCGACT  
AGCACTGACC**C**GCGGATGCTACGATCGACAT**C**GACGACACTAGCCGGGTACATCGATCACGCAT**A**GCGACT

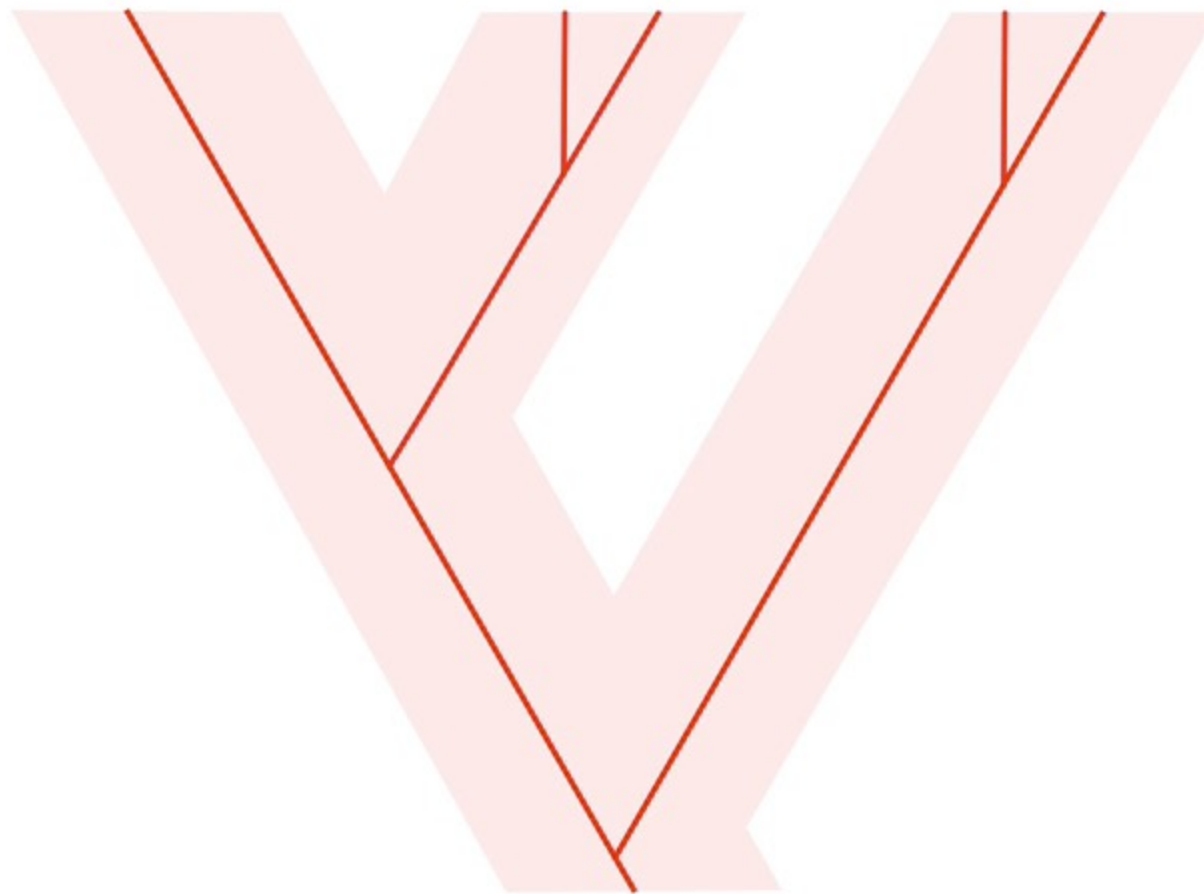

Animation courtesy of Kelsie Hunnicutt

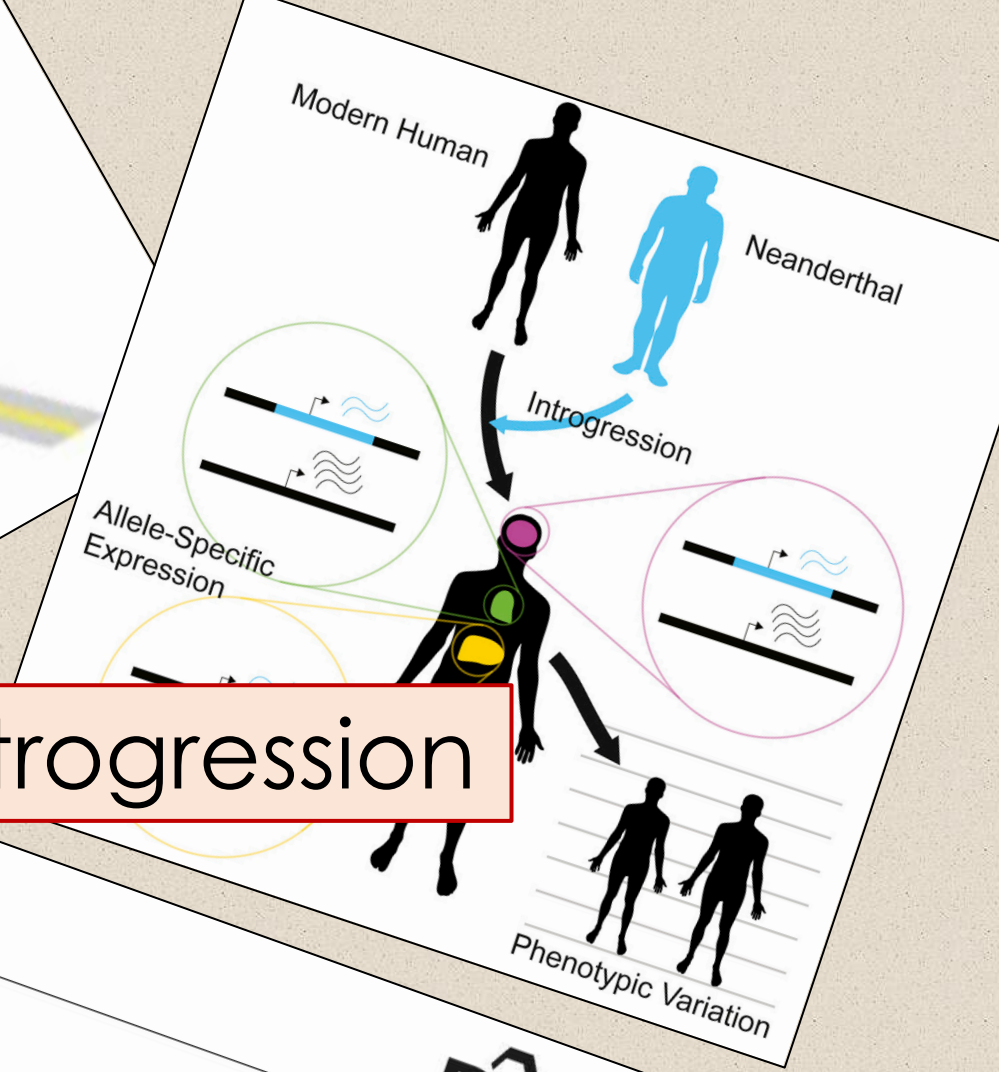
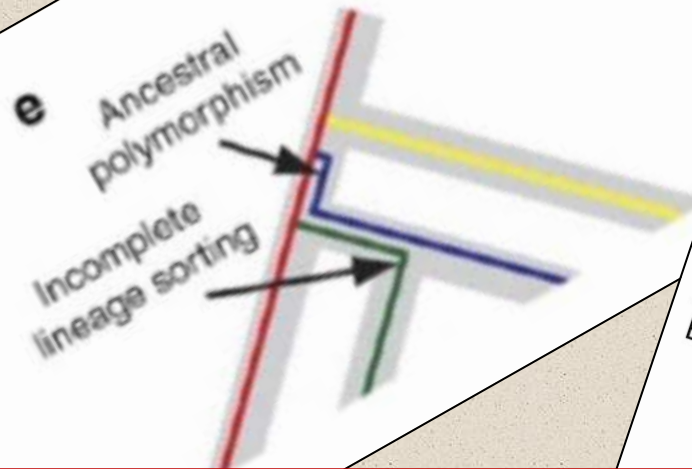
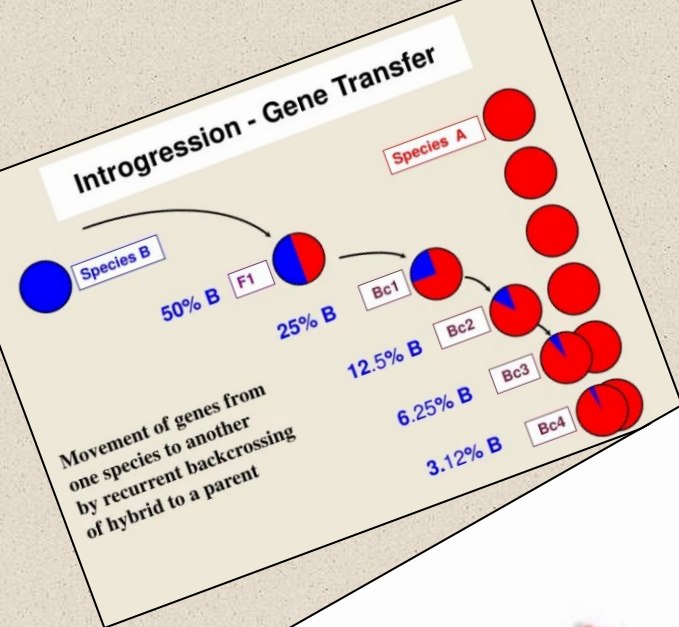

Weird non-sequitur on Introgression

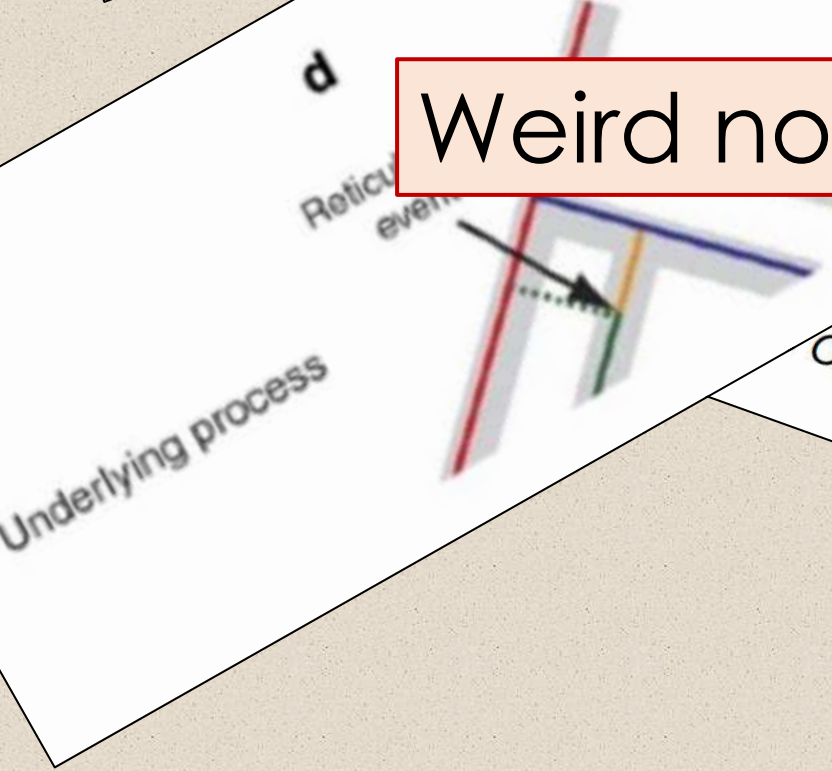

Introgression: Spooky Gene Flow in the Distant Past

Ottensburghs

BioEssays

www.bioessays-journal.com



Rachel Williams

Heredity (2020) 124:236–251  
<https://doi.org/10.1038/s41437-019-0260-9>

ARTICLE



## Conservation genomic analysis reveals ancient introgression and declining levels of genetic diversity in Madagascar's hibernating dwarf lemurs

Rachel C. Williams<sup>1,2</sup> · Marina B. Blanco<sup>1,2</sup> · Jelmer W. Poelstra<sup>1</sup> · Kelsie E. Hunnicutt<sup>3</sup> · Aaron A. Comeault<sup>4,5</sup> · Anne D. Yoder<sup>1,2</sup>

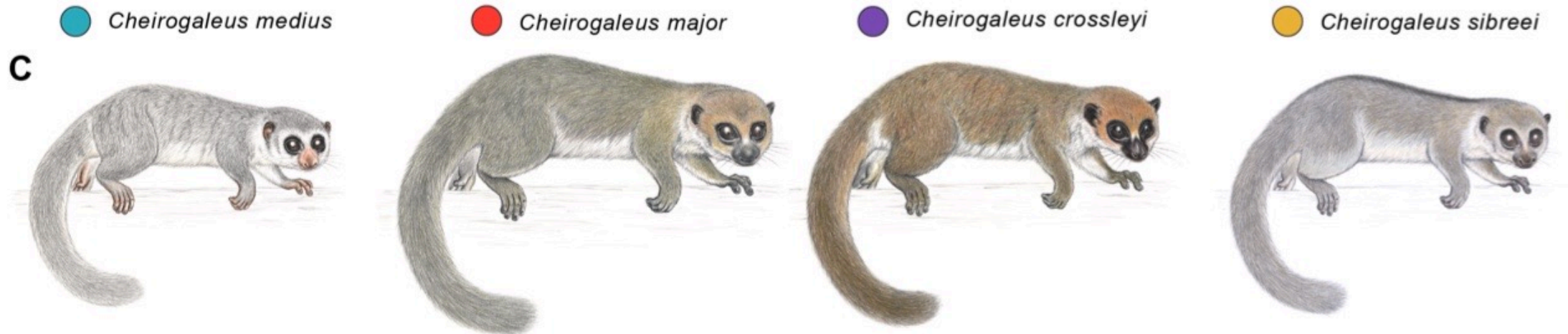

**Table S4.** Gene ontology results for introgressed regions of the genome for tests between *Cheirogaleus medius/C. major*, and *C. medius/C. sibreei*. All results are significantly over enriched for both tests respectively ( $p < 0.00006$ ,  $p < 0.00009$ ).

	GO category	FDR	Count	Total	GO description
<i>C. med/C. maj</i>	GO:0000122	7.30E-20	73	505	negative regulation of transcription from RNA polymerase II promoter
	GO:0000978	1.00E-13	50	328	RNA polymerase II core promoter proximal region sequence-specific DNA binding
	GO:0001078	1.70E-13	27	93	transcriptional repressor activity, RNA polymerase II core promoter proximal region sequence-specific binding
	GO:0043565	1.27E-09	39	270	sequence-specific DNA binding
	GO:0000977	1.88E-08	28	160	RNA polymerase II regulatory region sequence-specific DNA binding
	GO:0001227	1.88E-08	17	55	transcriptional repressor activity, RNA polymerase II transcription regulatory region sequence-specific binding
	GO:0005634	1.88E-08	154	2496	nucleus
	GO:0004993	1.90E-07	7	7	G-protein coupled serotonin receptor activity
	GO:0001228	4.44E-05	18	99	transcriptional activator activity, RNA polymerase II transcription regulatory region sequence-specific binding
	GO:0045892	7.19E-05			
	GO:0045944	8.23E-05			
	GO:0045893	8.25E-05			
	GO:0044212	0.000135577			
	GO:0051378	0.000444776			
	GO:0003677	0.000762117			
	GO:0003700	0.00134417			
	GO:0016339	0.003062617			
	GO:0070577	0.003062617			
	GO:0007156	0.004020354			
	GO:0008202	0.005942195			
	GO:0035240	0.00624982			
	GO:0051923	0.00624982			
	GO:0006355	0.006679222			
	GO:0007193	0.022140053			
	GO:0008146	0.02581555			
	GO:0001077	0.02581555			
	GO:0004952	0.02581555			
	GO:0004985	0.02581555			
	GO:0008504	0.02581555			
	GO:0042613	0.030175566			

Using D-Statistics  
 $p < 0.00006$ ,  $p < 0.00009$

# Ancient Introgression in mouse lemurs (*Cheirogaleidae Microcebus*) explains 20 years of phylogenetic uncertainty.

Blake Fauskee, Andrew A. Crowl, Bryan Piatkowski, Anne D. Yoder, George P. Tiley

Fig. 1

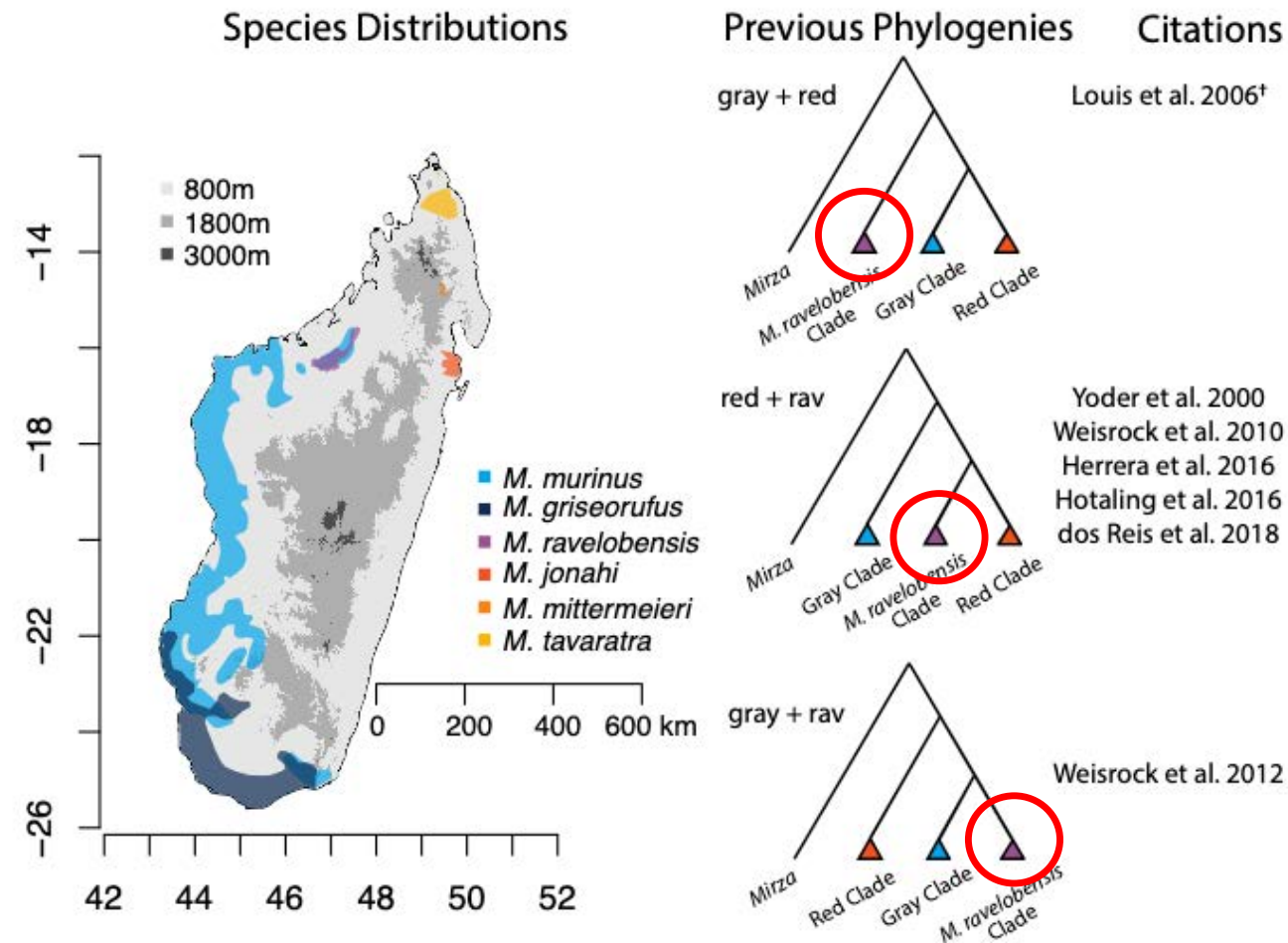



Article

# A Pervasive History of Gene Flow in Madagascar's True Lemurs (Genus *Eulemur*)

Kathryn M. Everson <sup>1,2,\*</sup> , Mariah E. Donohue <sup>2</sup>  and David W. Weisrock <sup>2</sup> 

**Nuclear Phylogeny (IQ-TREE)**

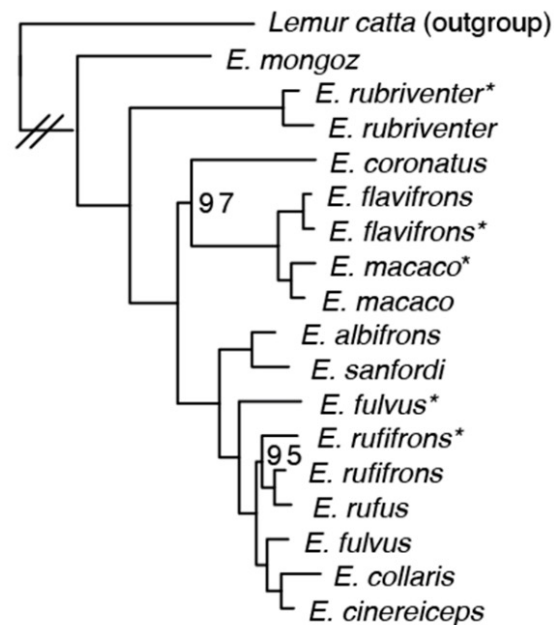

(a)

**Nuclear Species Tree (ASTRAL)**

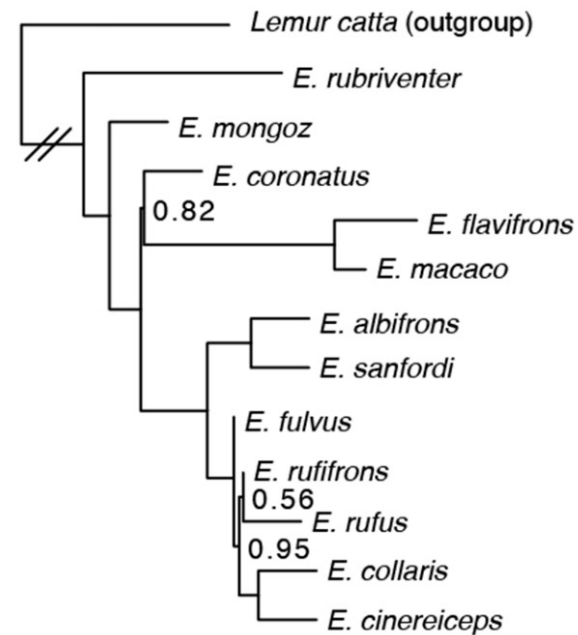

(b)

**Nuclear Species Tree (SVD-Quartets)**

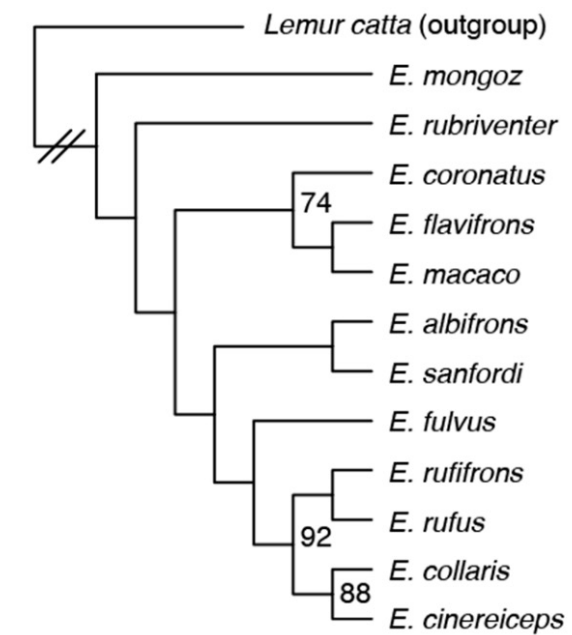

(c)

Article

# A Pervasive History of Gene Flow in Madagascar's True Lemurs (Genus *Eulemur*)

Kathryn M. Everson <sup>1,2,\*</sup> , Mariah E. Donohue <sup>2</sup>  and David W. Weisrock <sup>2</sup> 

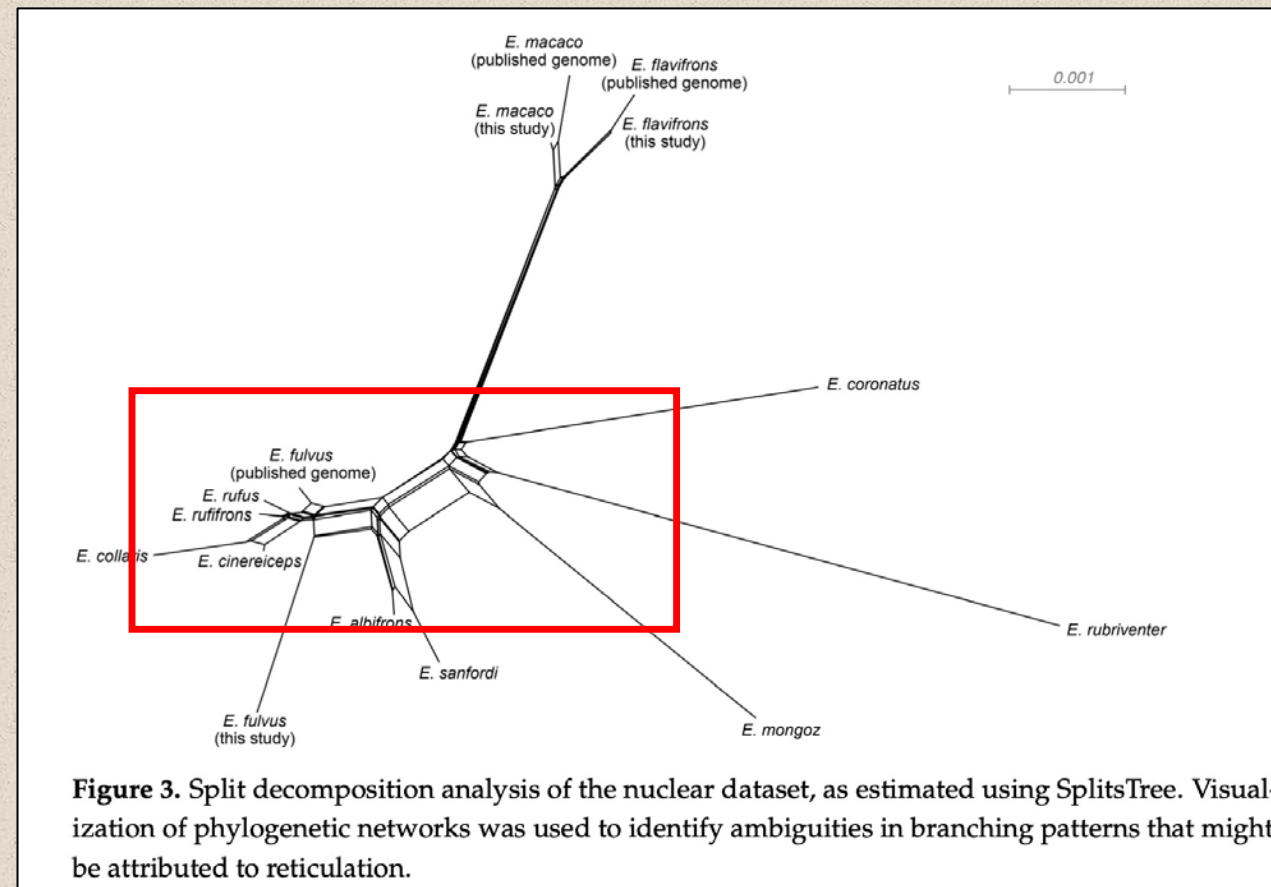

**Figure 3.** Split decomposition analysis of the nuclear dataset, as estimated using SplitsTree. Visualization of phylogenetic networks was used to identify ambiguities in branching patterns that might be attributed to reticulation.

(implicit)



1 Questioning Neanderthal admixture: on models, robustness  
2 and consensus in human evolution

3 Rémi Tournebize<sup>1,\*</sup> Lounès Chikhi<sup>2,1</sup>

4 April 5, 2023

“A major issue is that these methods have been poorly tested in the context of population structure, despite its widespread occurrence in many vertebrate species. We simulated data under a structured model and found that all tested methods identified spurious admixture events, suggesting a lack of robustness to population structure. Besides, our structured model was better at predicting several key genomic statistics than the tested admixture models. **This suggests that admixture should be re-evaluated in the light of population structure, in hominins and beyond.**”

## **The MSC is increasingly used for:**

- Species delimitation
- Reconstructing historical demography (e.g., ancestral population size)
- Patterns of gene flow among and between phylogenetic lineages
- Phylogeny reconstruction
- Divergence time estimation

# Thank you, Peter, Laura, and Claudia!

In no particular order ...

- The coalescent is a powerful tool for understanding historical demography (e.g., ancestral  $N_e$  and divergence times)
- Branch lengths can have an enormous impact on recovering the species tree from gene trees
- Rapid radiations with short internal branches can really F\* U up!
- Ancestral population size (the size of “the box”) can have a huge impact on coalescent rates
- Assumed mutation rate can have HUGE impact on estimation of  $N_e$
- Increasingly clear that concatenation is inferior to MSC for estimating species tree
- Theoretically, coalescent times should be as old or older than speciation events

Ideally, we want multiple loci  
that are independently  
segregating in the genome

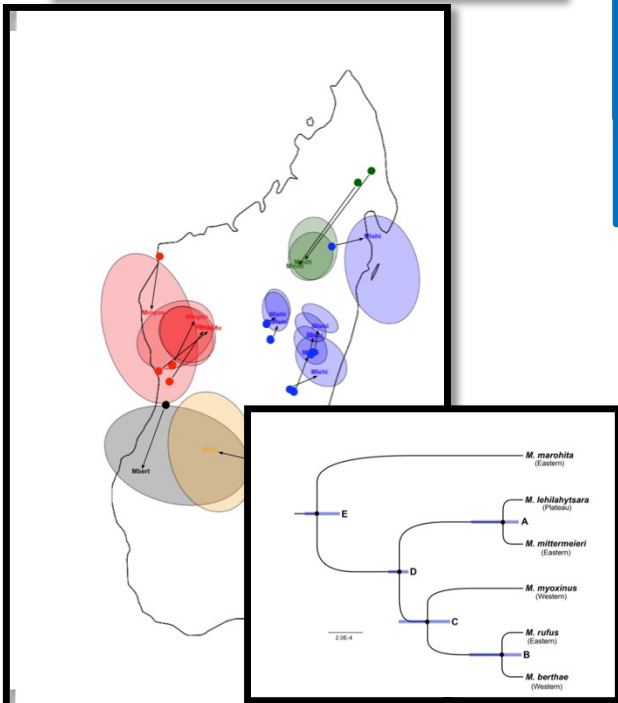
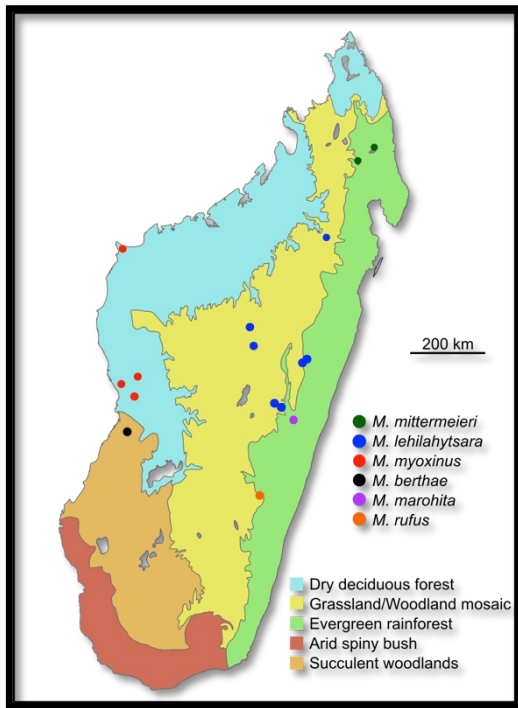

Library  
Prep

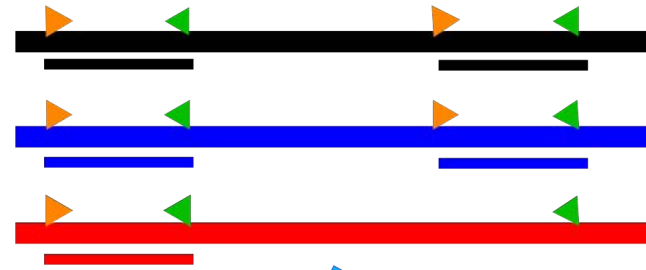

NextGen  
Sequencing

RADseq: Tens of thousands of unlinked SNPs from across the genome!

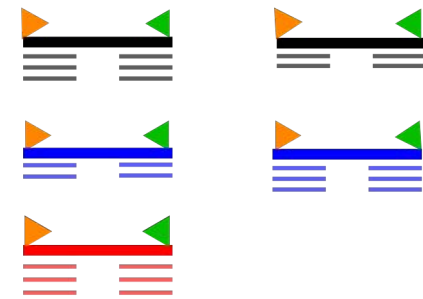

Cluster  
Data/Call  
SNPs

Data  
Types

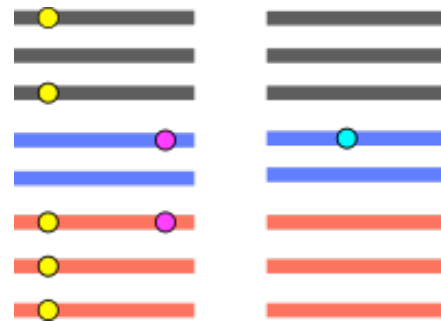

# RADseq Stats

## *Filtering thresholds:*

- **Invariant loci are retained**; minimum locus size: 100; maximum % of missing data: 10.
- Total number of loci (that passed filtering): **15,267**.
- **# of invariant loci: 1,822.**

*Mean locus length: 231 bp.*

*Mean # of variable sites: 4.7.*

*Mean # of parsimony-informative sites: 3.29.*

*Mean % of missing data (Ns): 5.53.*







# Though sampling strategy must be carefully considered! (E.g., frogs in a single pond ...)

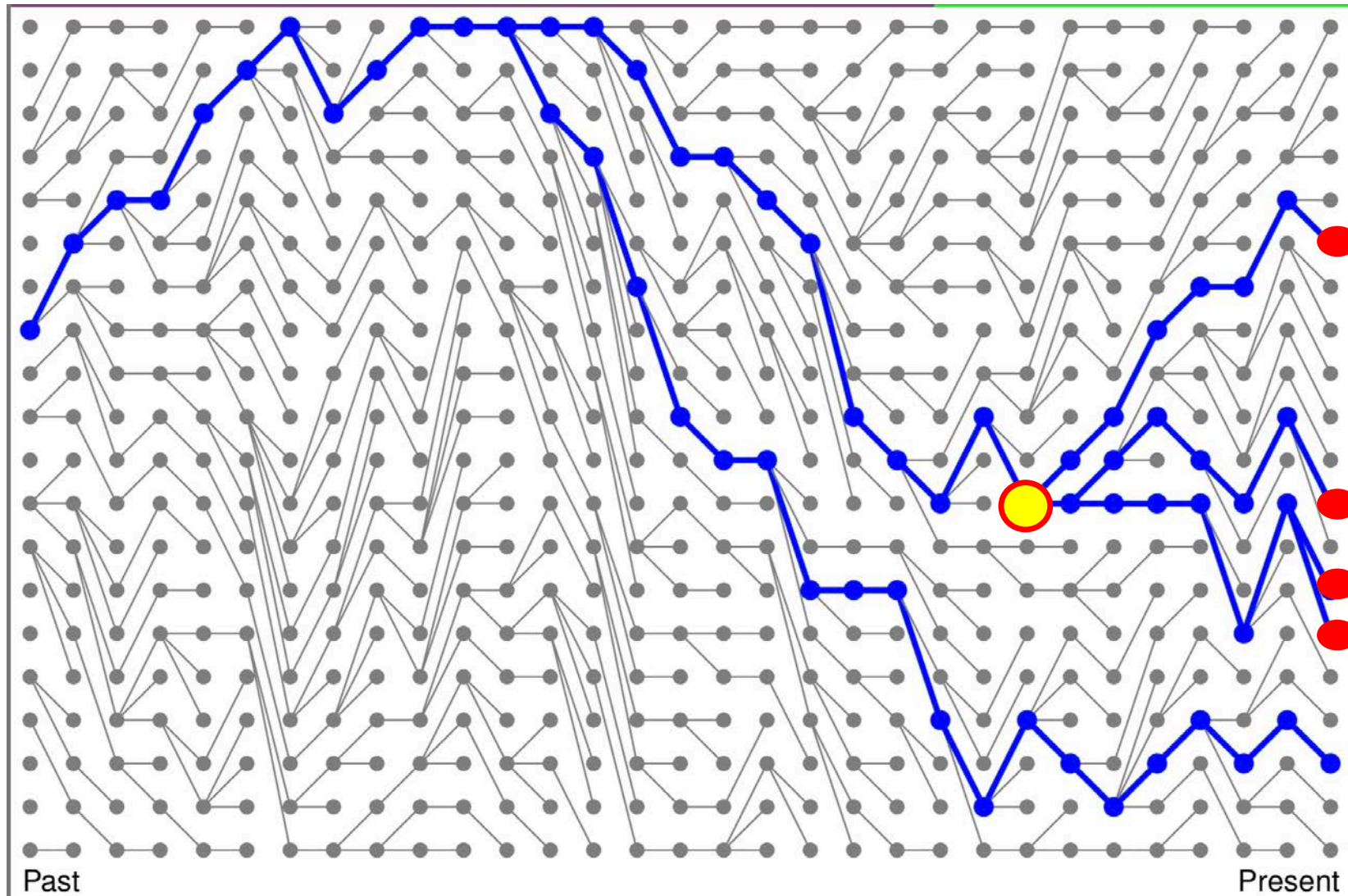

Thanks to  
Peter Beerli  
(MOLE 2022)

# But sampling from TWO ponds can yield older coalescent events, even with fewer individuals

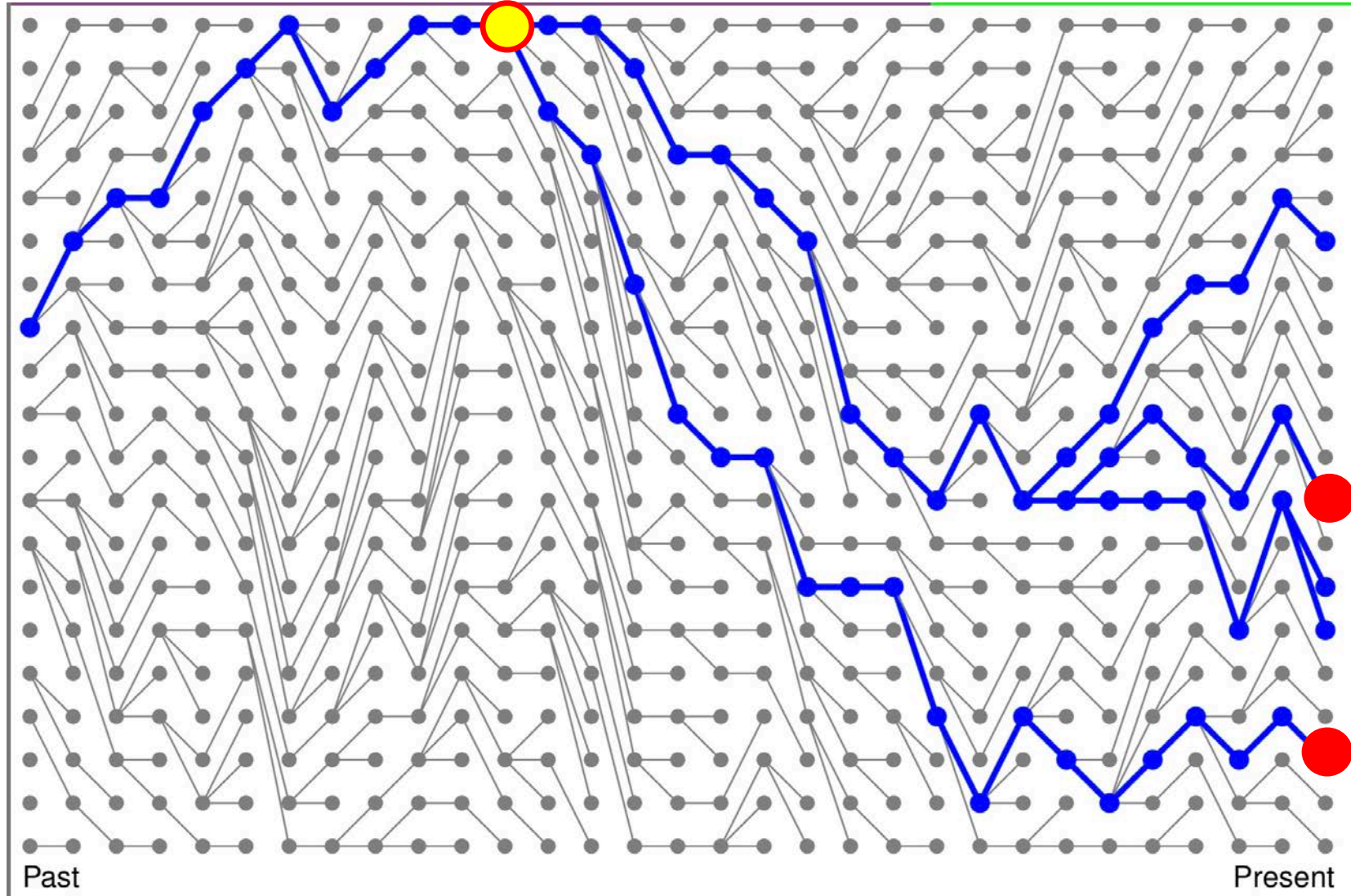

Thanks to  
Peter Beerli  
(MOLE 2022)

Portugal  
(Oeiras)



Lounès Chikhi

France  
(Toulouse)



Jordi Salmons

Ute Radespiel



Germany  
(Hannover)



USA  
(Durham)

# RADseq Consortium

---



M. sp. - Montagne d'Ambre from Montagne d'Ambre M. sp. - Montagne d'Ambre from Montagne d'Ambre

M. sp. - Montagne d'Ambre from Montagne d'Ambre M. sp. - Montagne d'Ambre from Ambanja

M. mittermeieri from Anjanaharibe Sud M. mittermeieri from Anjanaharibe Sud

M. myoxinus from Andranomanitsy Marojejy Anjanaharibe Sud

M. myoxinus from Andranomanitsy M. ravelobensis from Ankarafantsika

C. crossleyi from Ankafobe Mlehi (4)

M. lehilahytsara from Ankafobe

M. myoxinus from Aboalimena M. myoxinus from Aboalimena

M. myoxinus from Aboalimena M. myoxinus from Aboalimena

M. murinus from Andranomena M. lehilahytsara from Tsinjoarivo

M. murinus from Manakobay M. murinus from Belo-sur-mer

M. rufus from Andrambovato Mruf (3)

M. rufus from Andrambovato M. rufus from Andrambovato

M. murinus from Vohimena M. murinus from Vohimena

M. murinus from Vohimena M. murinus from Vohimena

M. griseorufus from Beza Mahafaly Mmyox (1)

M. griseorufus from Vombositse M. griseorufus from Vombositse

M. griseorufus from Tsimanampetsotsa M. griseorufus from Vohondava

M. griseorufus from Tongaenoro M. manitatra from Bemanasy

M. griseorufus from Mahavelo

N > 1000  
individuals from  
> 20 species

1997

18

# The ideal species concept – and why we can't get it

---

*D. L. Hull*

Contacting address: Department of Philosophy, Northwestern University, Evanston,  
IL 60208, USA

**Cohesion Species Concept**

**Biological Species Concept**

**Non-dimensional Species Concept**

**Ecological Species Concept**

**Morphological Species Concept**

**Genetic Species Concept**

**Recognition Species Concept**

**Phylogenetic Species Concept**

Col

Non-

M

Rec



cept

ncept

ncept

cept

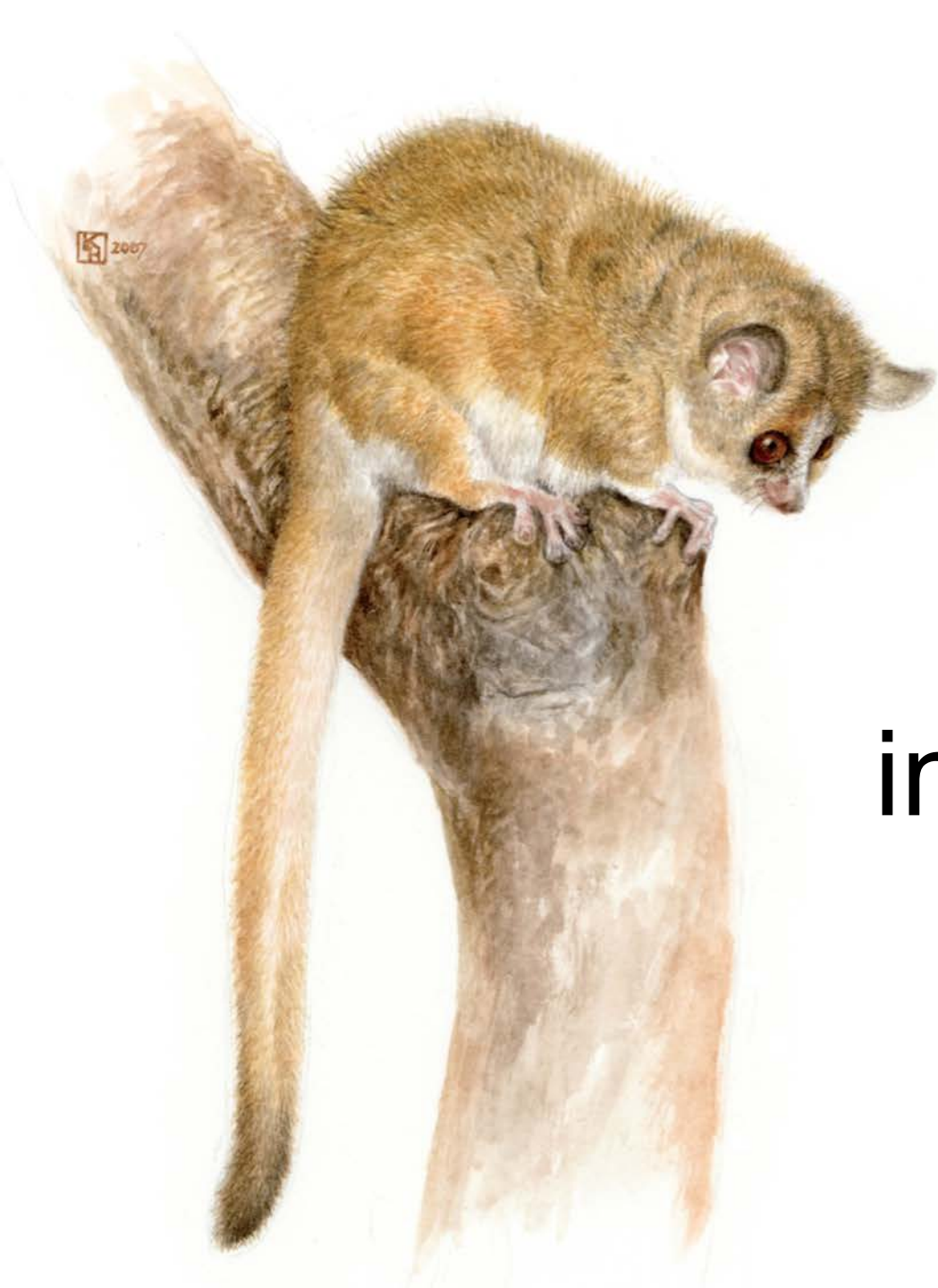

# Diversification and integrative taxonomy of mouse lemurs



## **Tools along the way:**

- Phylogenomics
- Phylogeography
- Demography
- Statistical genetics (MSC)
- Divergence time estimation
- Sensory biology
- Ecology (e.g., movement)

# Geographic Sampling & Phenotypic Analysis

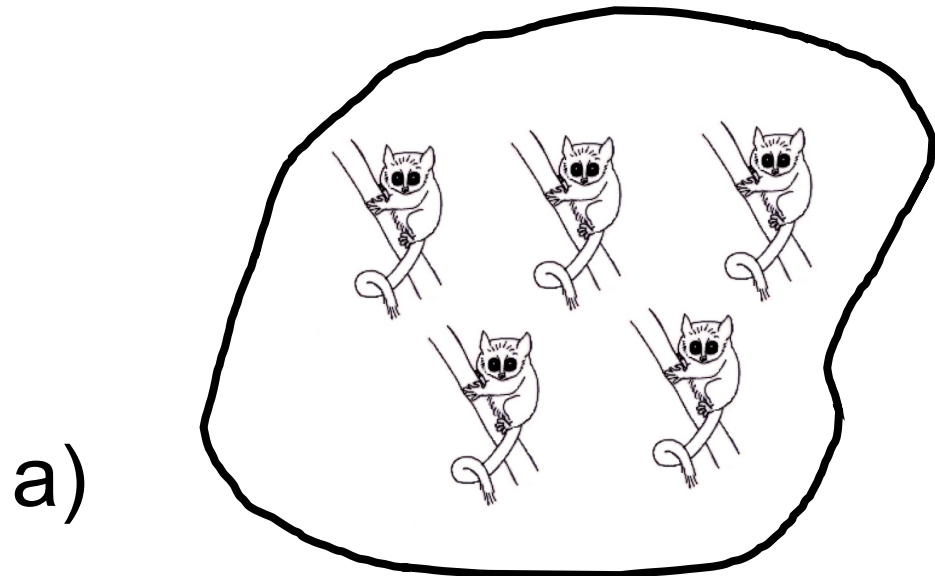

# mtDNA barcoding

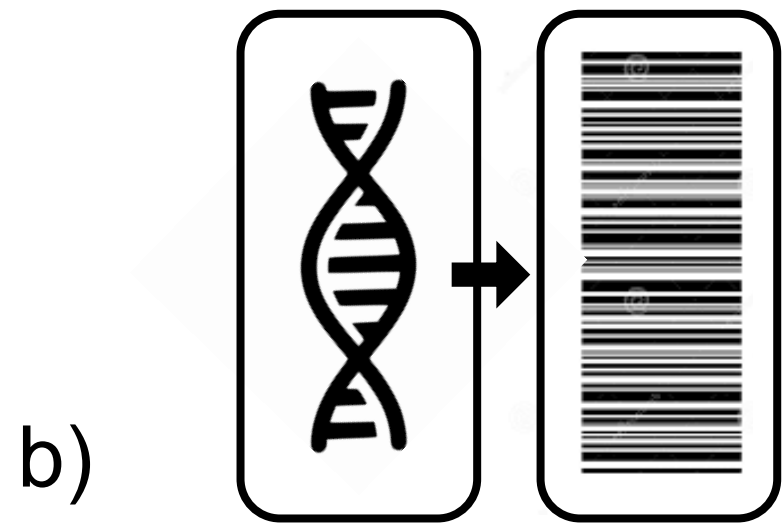

# Phylogenetically-guided Hypotheses

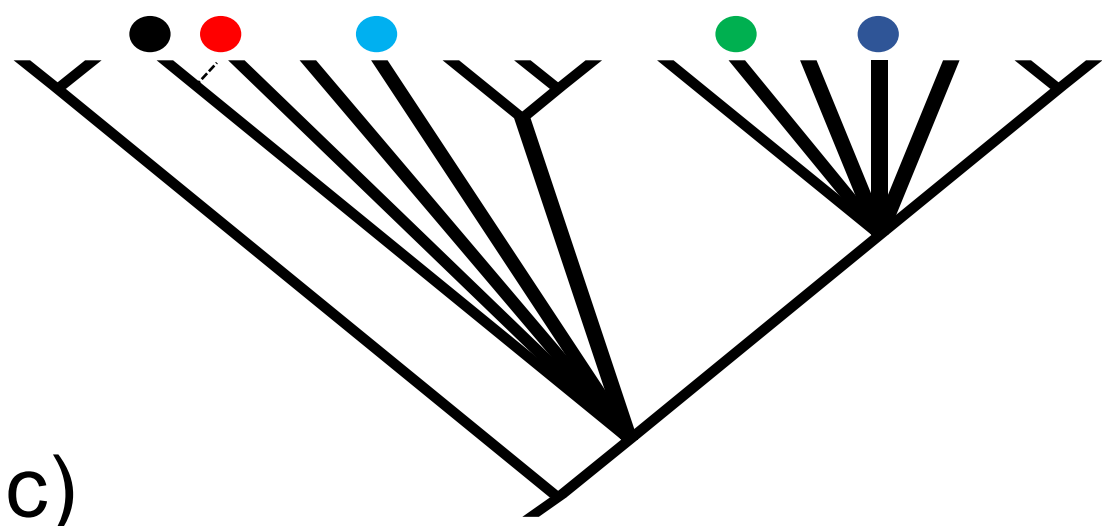

# Genomic Species Delimitation

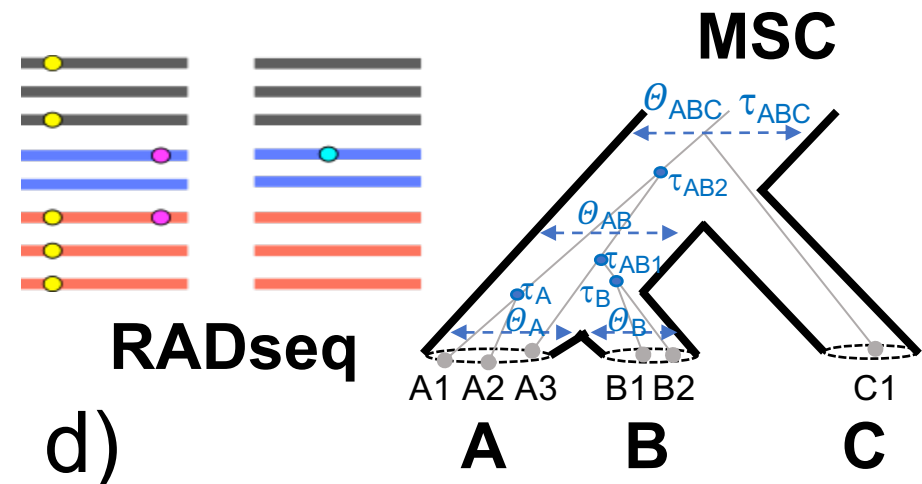



**Jordi Salmona**



**Tobias van Elst**

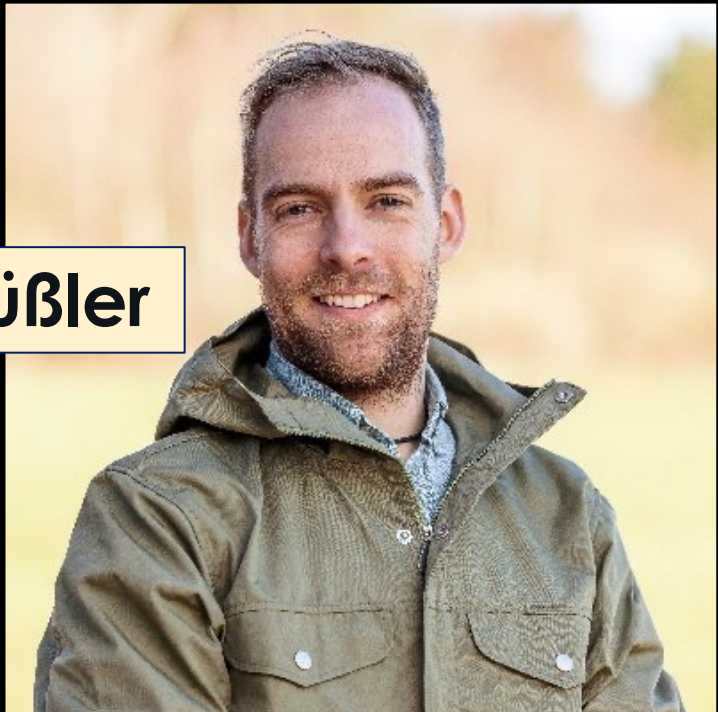

**Dominik Schüßler**



**Gabriele Sgarlata**

**So “crypsis” looks like it might be an active process: so what is driving lineage diversification?**

[Evolutionary Ecology](#)

July 2014, Volume 28, [Issue 4](#), pp 591–609 | [Cite as](#)

# Sensory drive speciation and patterns of variation at selectively neutral genes

Authors

[Authors and affiliations](#)

---

Tomotaka Matsumoto  , Yohey Terai, Norihiro Okada, Hidenori Tachida

“Speciation by sensory drive can occur if divergent adaptation of sensory systems causes rapid evolution of mating traits and the resulting development of assortative mating.”



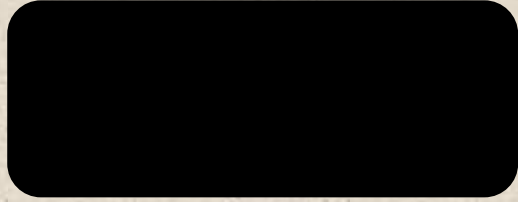

Sound



Smell

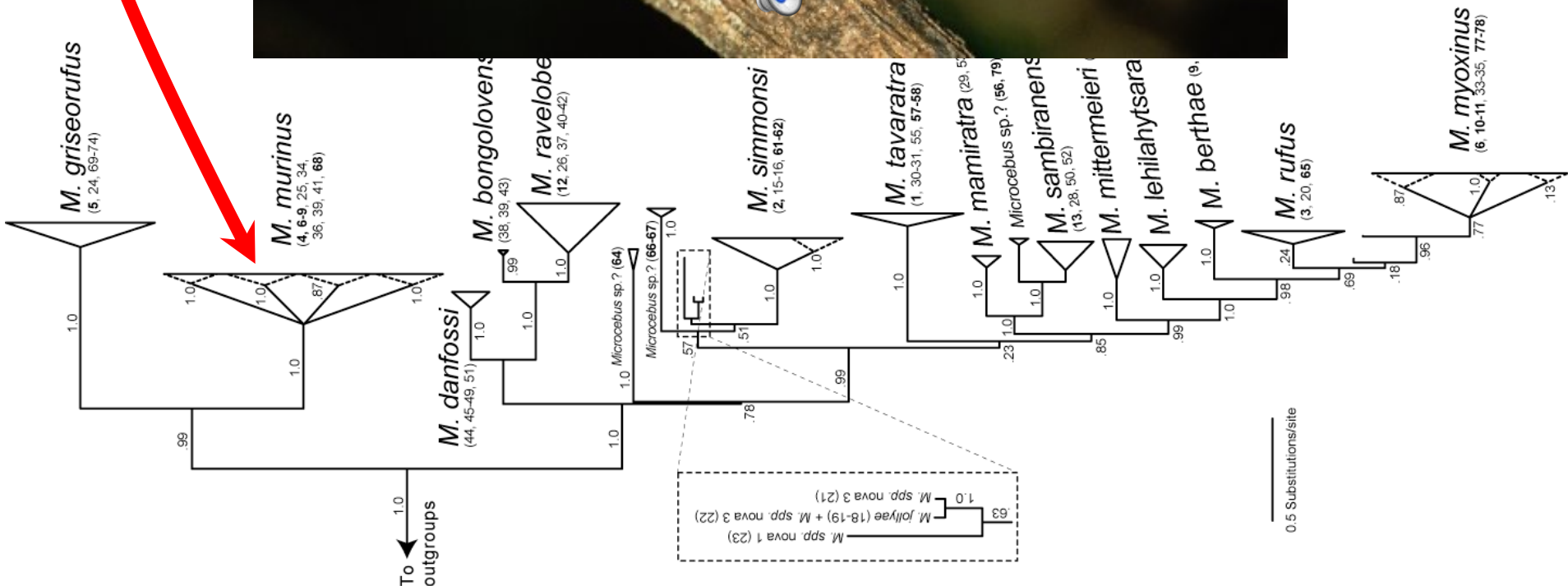



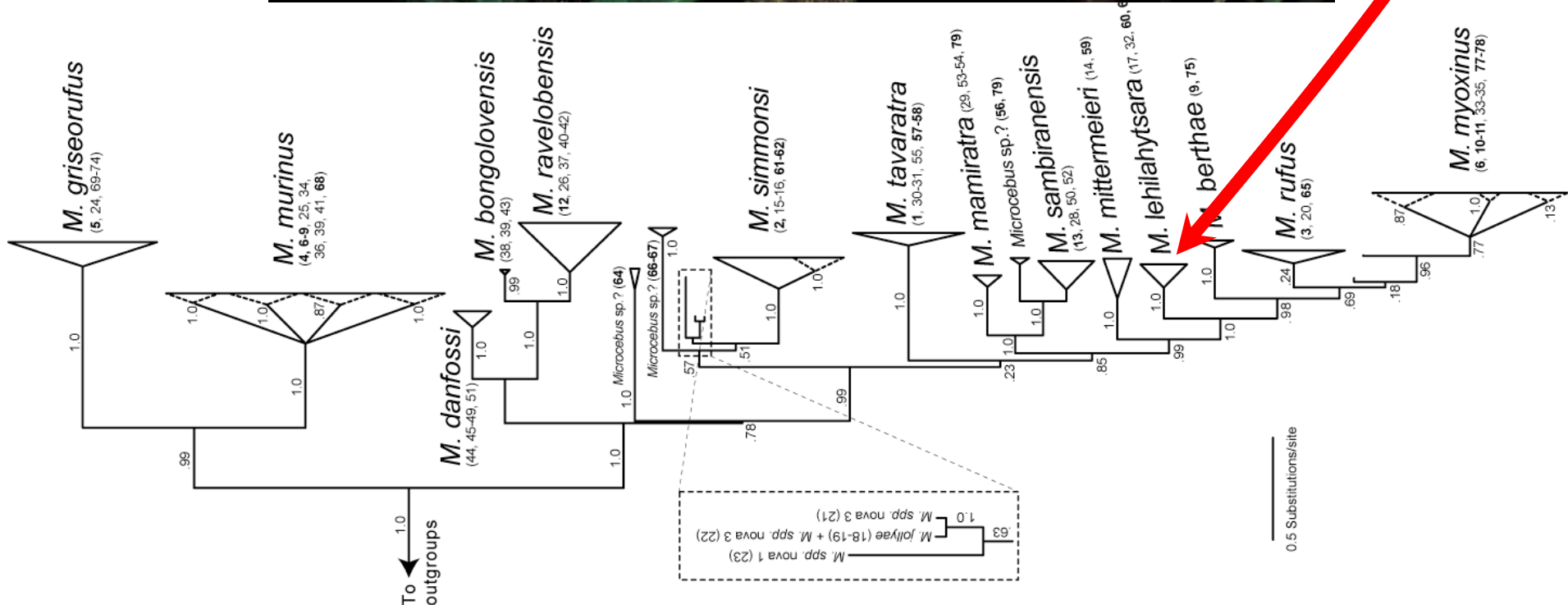

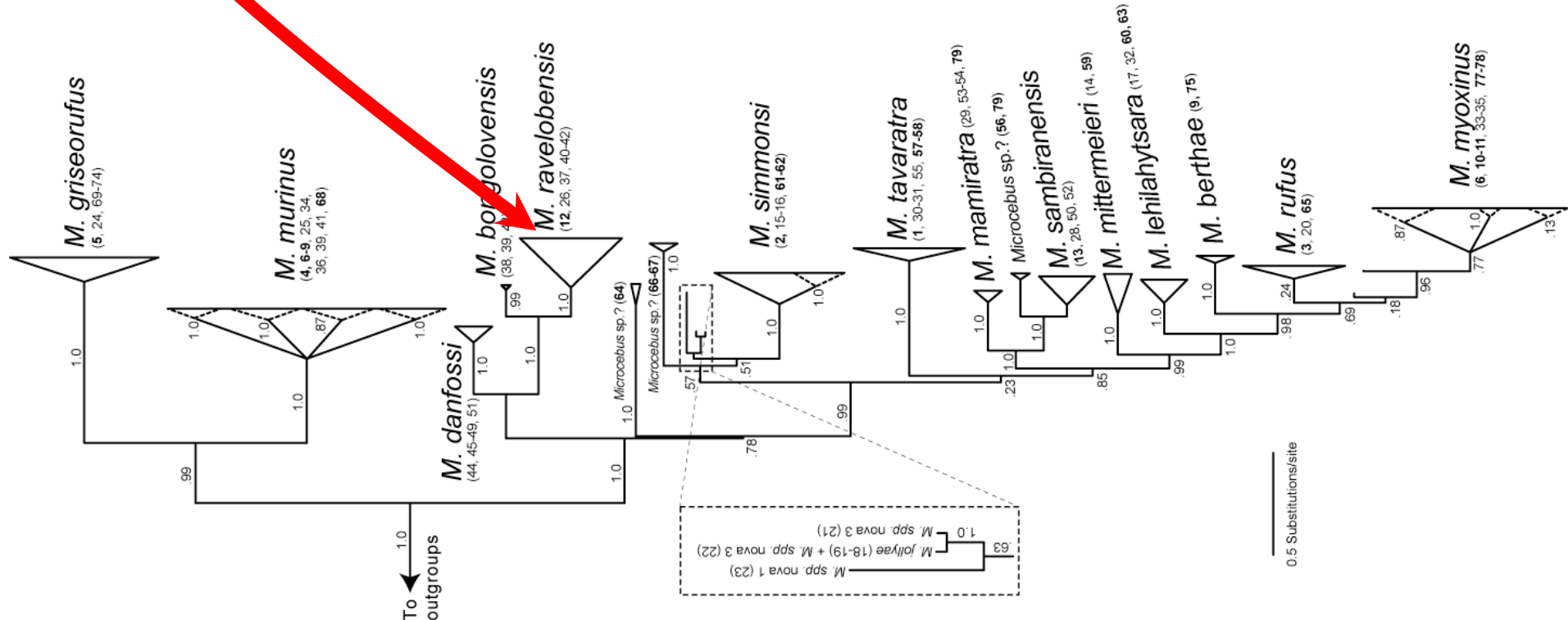

# Male advertisement calls for three species

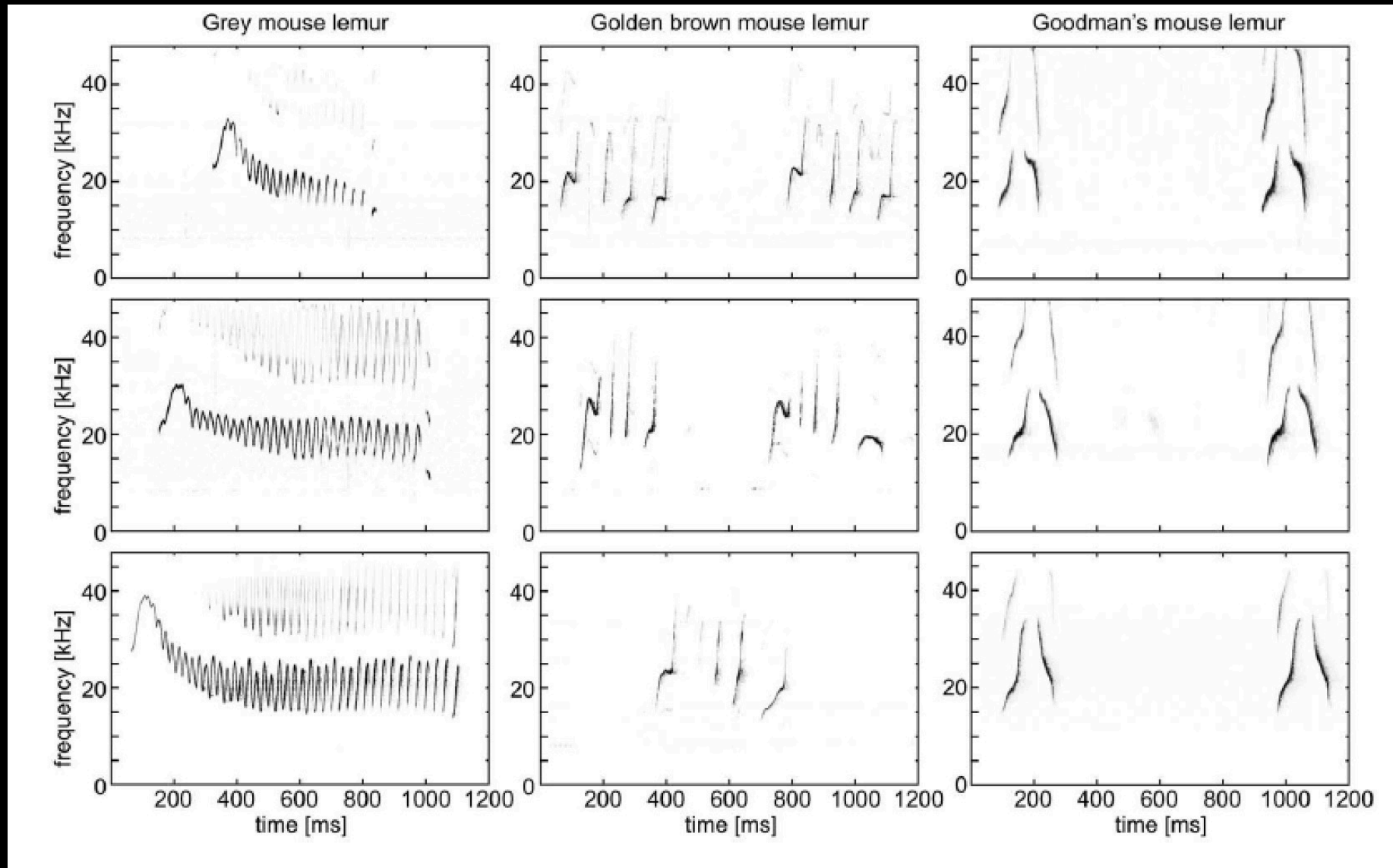

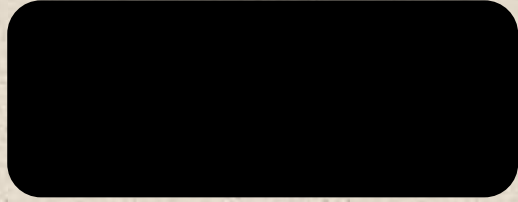

Sound



Smell





# Woods Hole, 2008

But how can I tell if they are receiving different olfactory signals???

I've been working on this really cool system called the vomeronasal receptor Class I genes (V1R)



# Molecular Evolutionary Characterization of a V1R Subfamily Unique to Strepsirrhine Primates

Anne D. Yoder<sup>1,\*</sup>, Lauren M. Chan<sup>1,†</sup>, Mario dos Reis<sup>2,†</sup>, Peter A. Larsen<sup>1,†</sup>, C. Ryan Campbell<sup>1</sup>, Rodin Rasoloarison<sup>3,4</sup>, Meredith Barrett<sup>5</sup>, Christian Roos<sup>4</sup>, Peter Kappeler<sup>6</sup>, Joseph Bielawski<sup>7</sup>, and Ziheng Yang<sup>2</sup>

<sup>1</sup>Department of Biology, Duke University

<sup>2</sup>Department of Genetics, Evolution and Environment, University College London, London, United Kingdom

<sup>3</sup>Département de Biologie Animale, Université d'Antananarivo, Antananarivo, Madagascar

<sup>4</sup>Gene Bank of Primates and Primate Genetics Laboratory, German Primate Center (DPZ), Göttingen, Germany

<sup>5</sup>UCSF Center for Health & Community

**V1Rstrep**

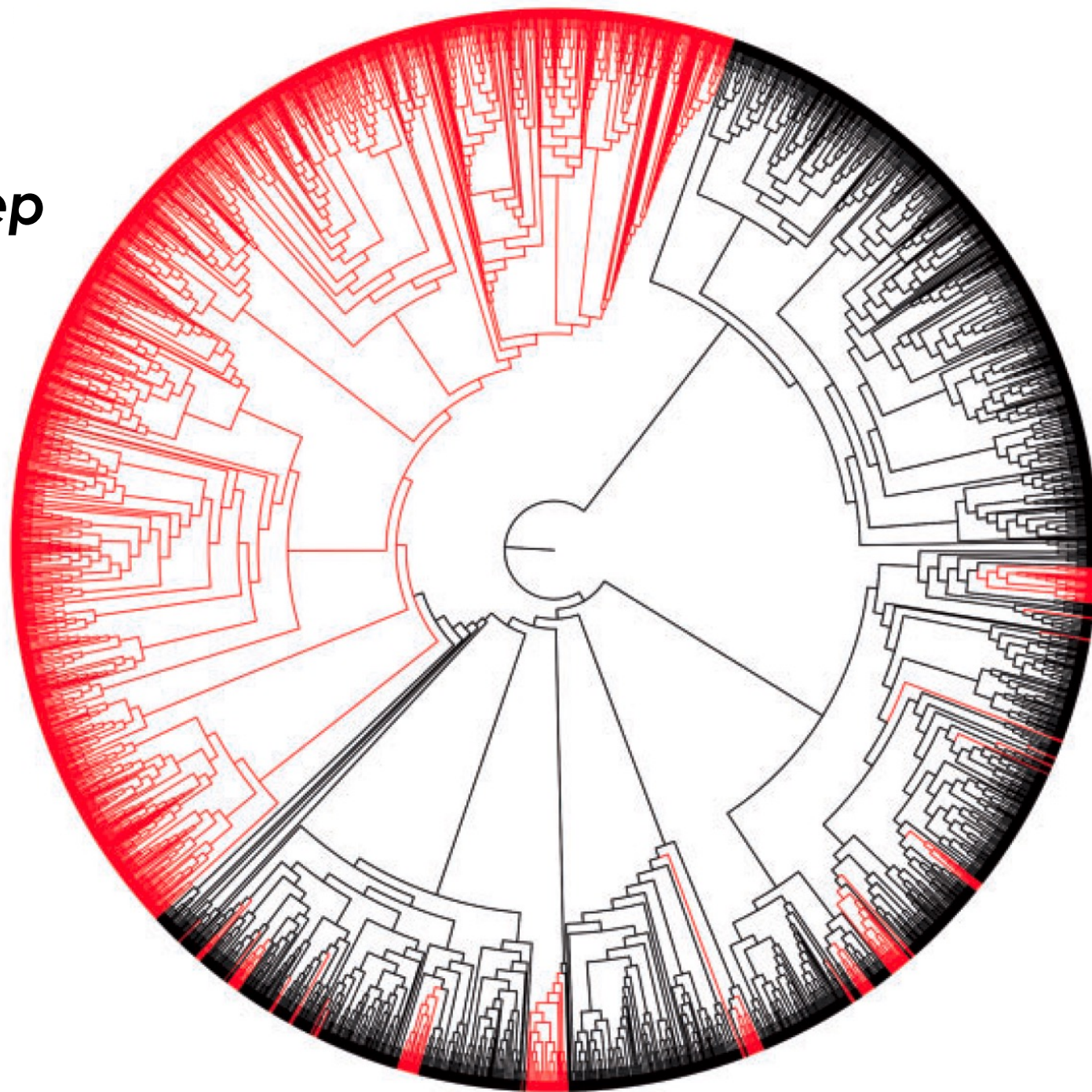



**Our hypothesis:** nocturnal primates (like mouse lemurs) will show higher diversity of V1Rs than will diurnal primates, and these gene copies will be under strong positive selection

**Our results:** based on targeted PCR, cloning, and Sanger sequencing we discovered a gene family, apparently unique to the strepsirrhines, that was under strong positive selection but did NOT show any particularly compelling patterns regarding nocturnality and diurnality



George Tiley

## V1R: Chapter 2



Kelsie Hunnicutt

GBE

### Comparative Genomic Analysis of the Pheromone Receptor Class 1 Family (V1R) Reveals Extreme Complexity in Mouse Lemurs (Genus, *Microcebus*) and a Chromosomal Hotspot across Mammals

Kelsie E. Hunnicutt<sup>1,8,†</sup>, George P. Tiley<sup>1,†</sup>, Rachel C. Williams<sup>1,2</sup>, Peter A. Larsen<sup>1,9</sup>, Marina B. Blanco<sup>2</sup>, Rodin M. Rasoloarison<sup>3,4</sup>, C. Ryan Campbell<sup>1</sup>, Kevin Zhu<sup>5</sup>, David W. Weisrock<sup>6</sup>, Hiroaki Matsunami<sup>5,7</sup>, and Anne D. Yoder<sup>1,\*</sup>

2019

# Hunnicutt, Tiley et al. (2019)

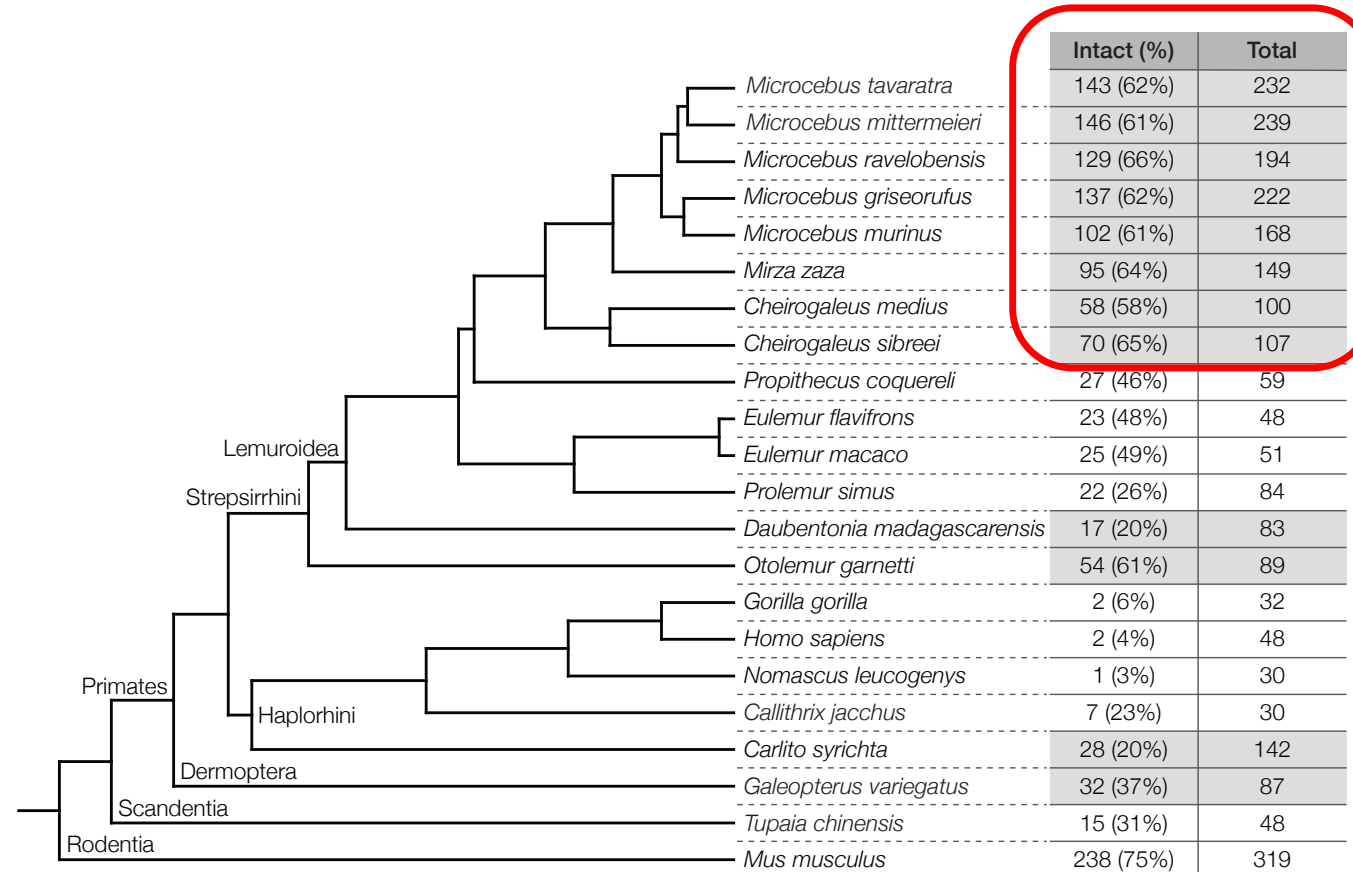

Whole genome analysis indicates that mouse and dwarf lemurs have the most diverse portfolio of V1Rs, with highest proportion of intact copies, in all of primates.

GPCR  
Pheromone  
receptors

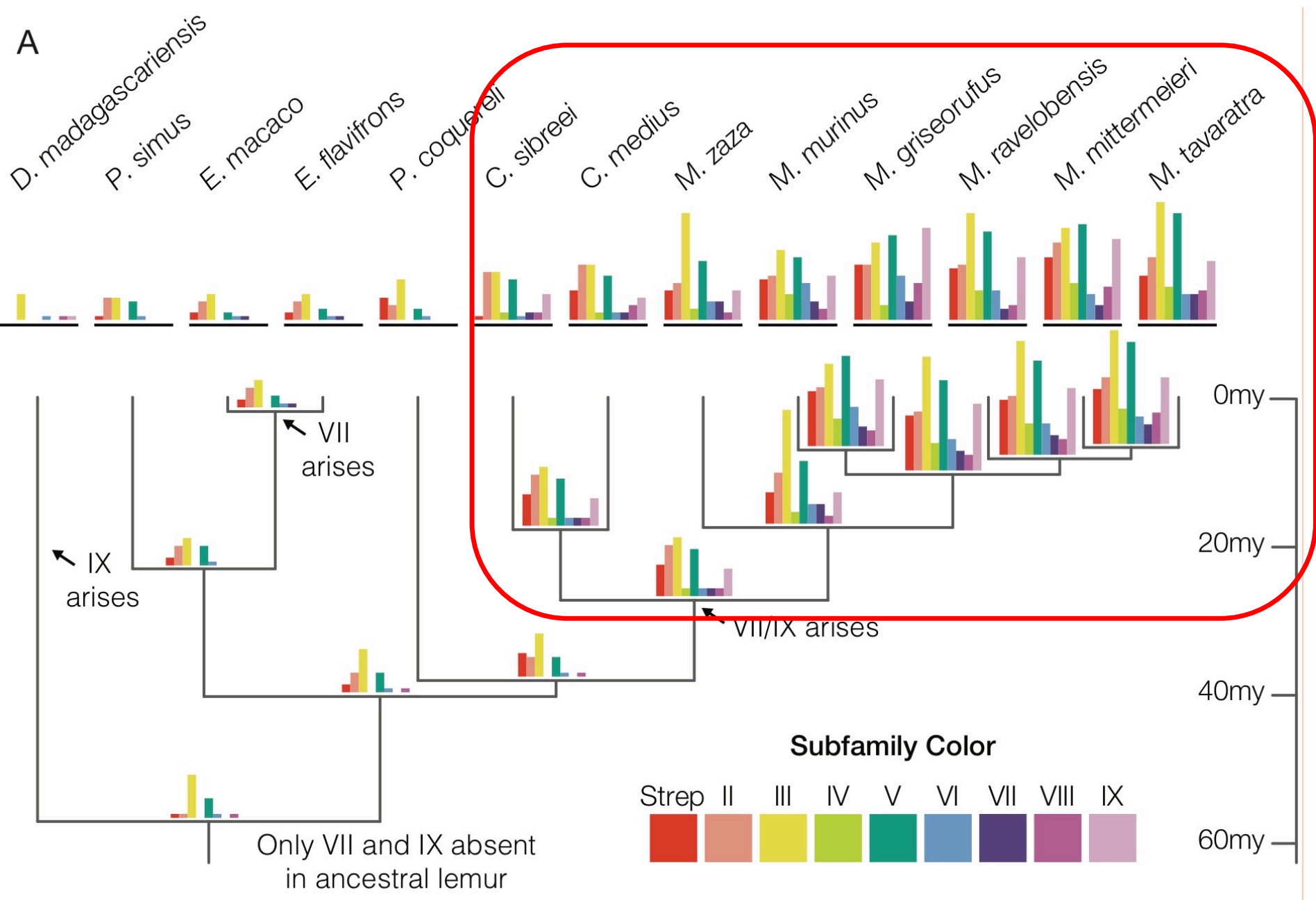

**For me, it always begins with a “date”**

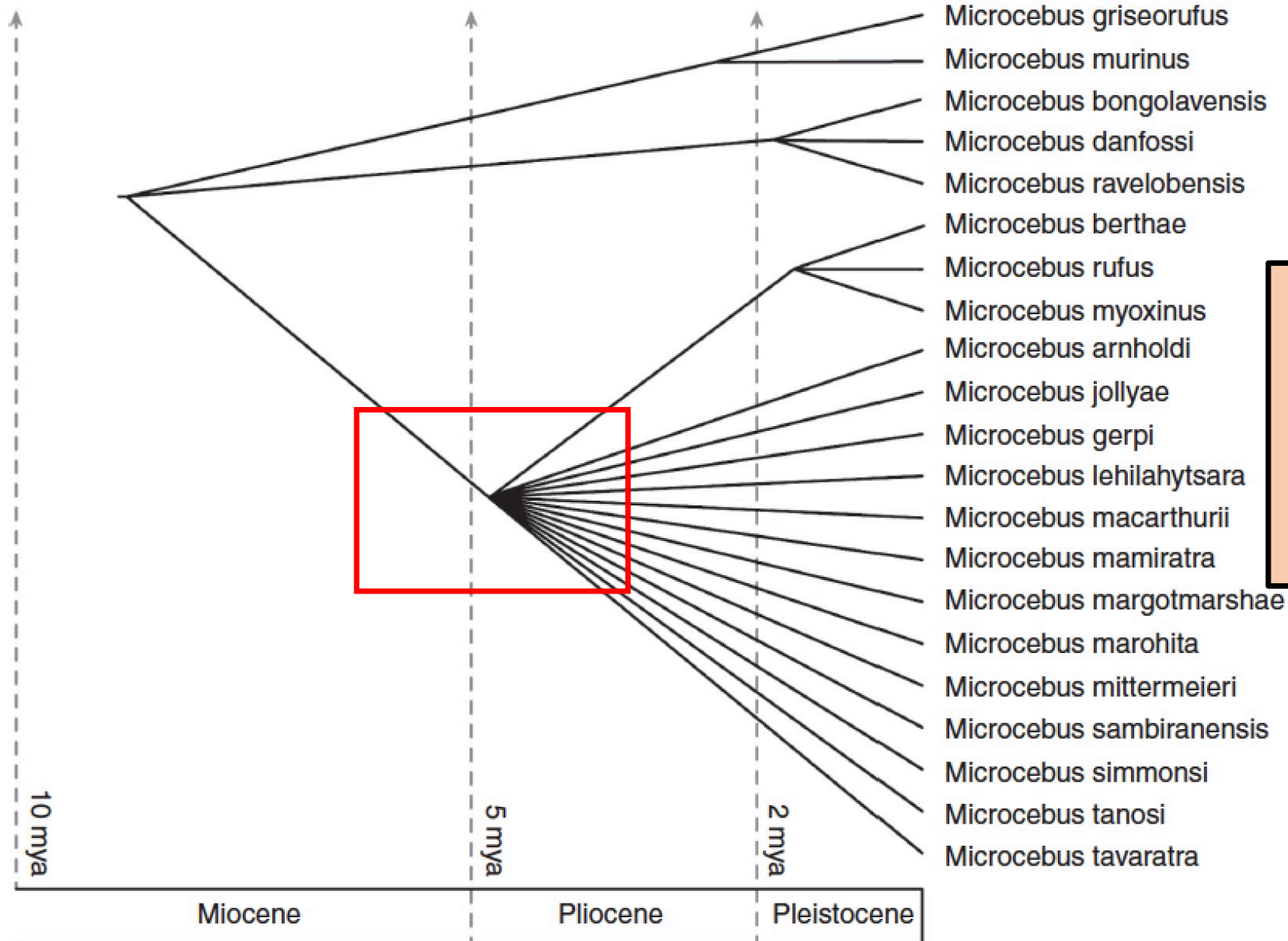

“The anomaly zone”  
where gene trees are  
more likely to be  
recovered than the  
species tree

# Phylogenetic resolution is highly sensitive to sample of chosen loci in concatenated phylogenetic analysis (in mouse lemurs)



Dave Weisrock

B) Concatenated nuclear and mitochondrial data

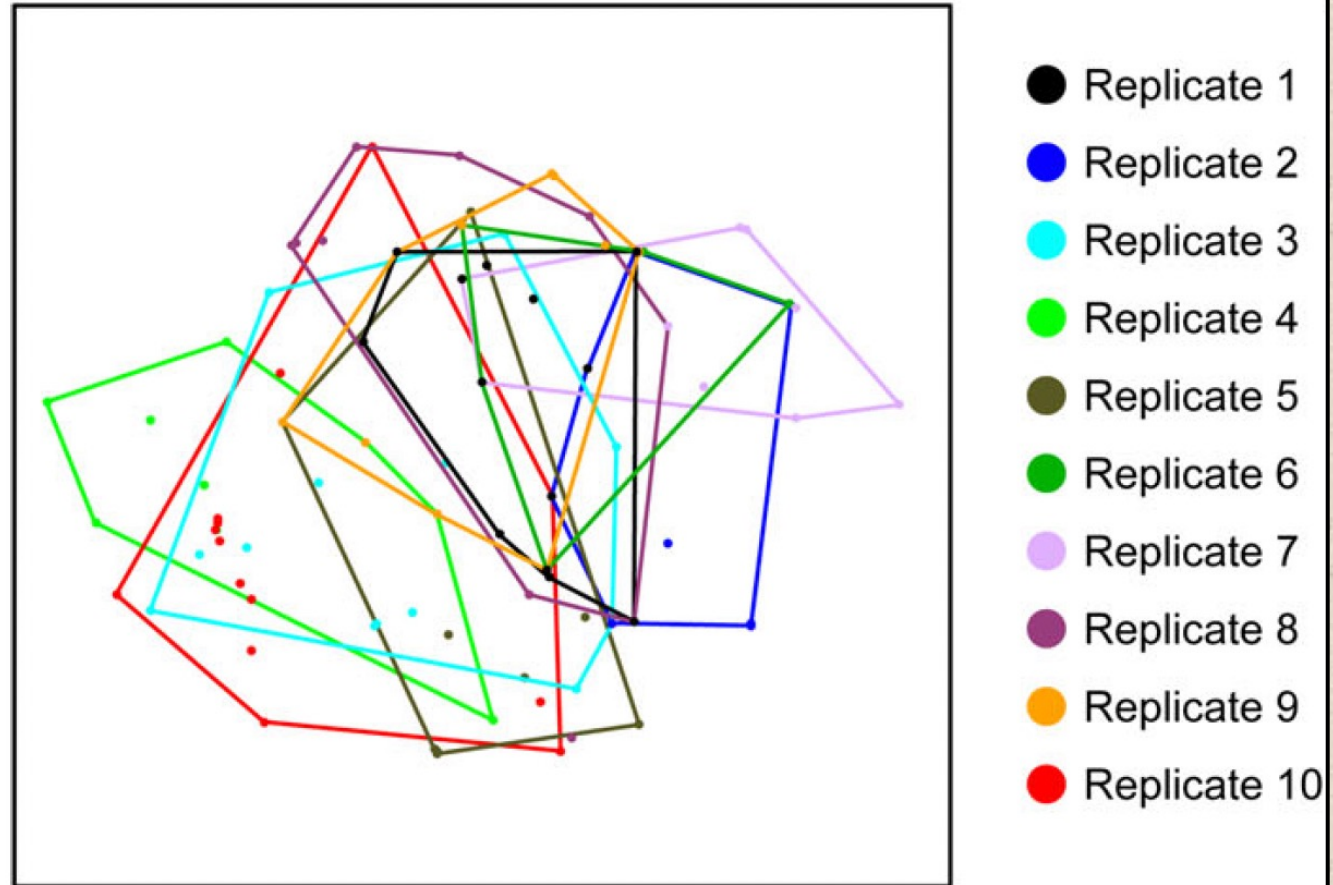

# Has climate change been a driver of speciation?

## Climate Fluctuation during the Pleistocene

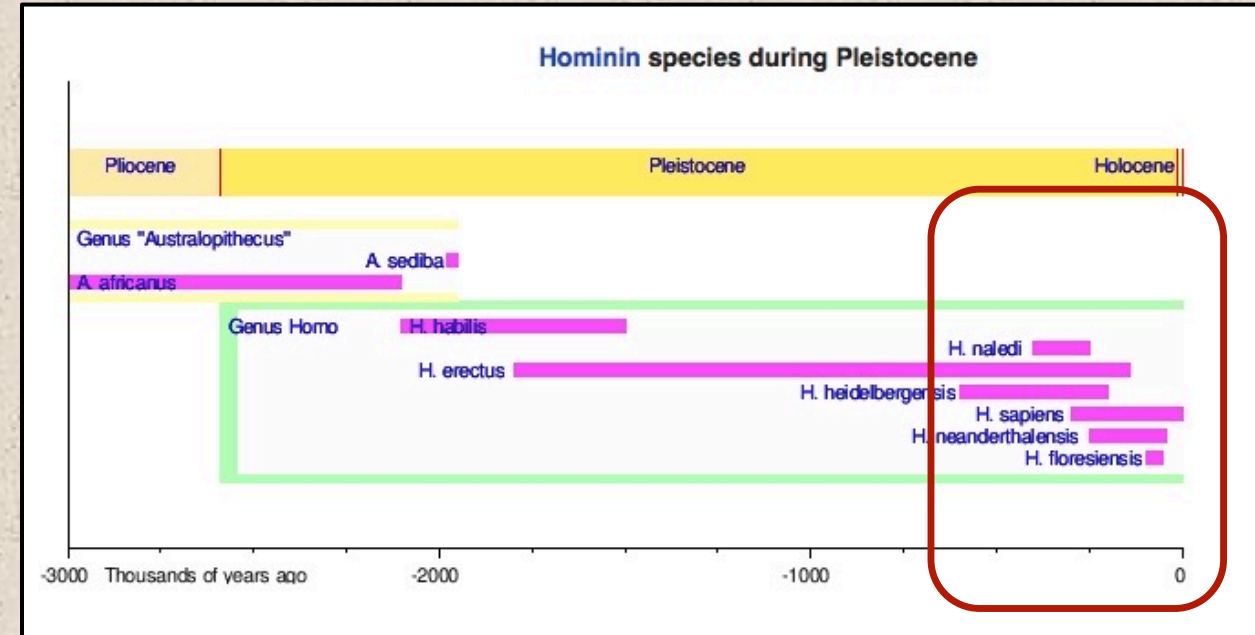
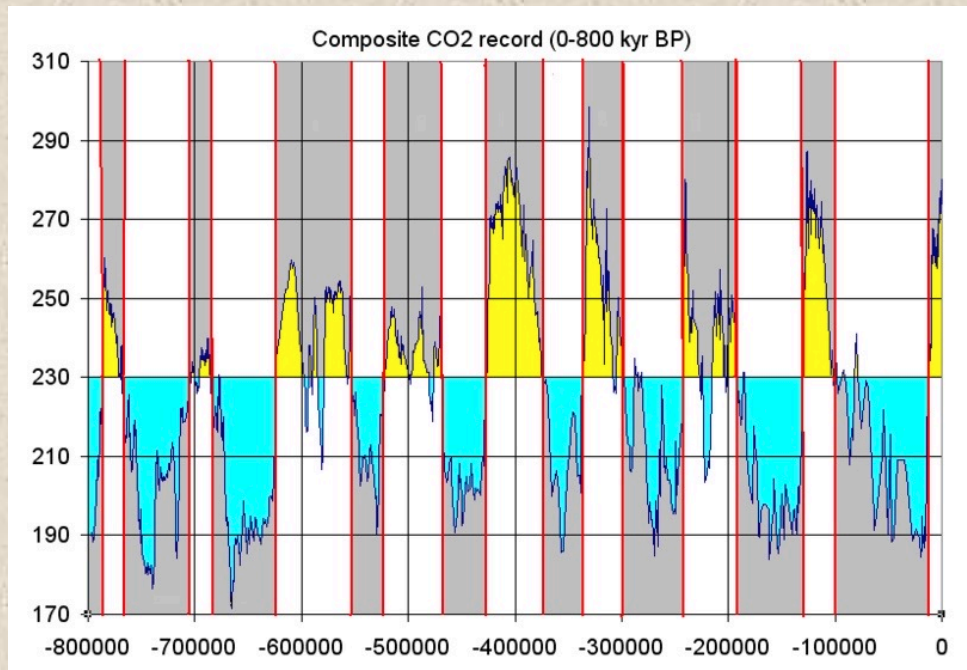

Lineage diversification within hominins

~ 2.6 mya through ~ 12 kya



**If this model is “correct”  
the age of the splits should  
be of the appropriate age  
(just for starters)**

Concatenated likelihood methods estimate the age of the mouse lemur radiation to be ~ 8 – 13 Ma



**Recall that there is no fossil  
record!!!**

# How to calibrate coalescent trees to geological time

Jul 3, 2016 • Mario dos Reis



Simple overview:

By using estimates of **mutation rate** and **generation time** we can calculate absolute time of divergence (without fossil calibrations!) ars.

# How to calibrate coalescent trees to geological time

Jul 3, 2016 · Mario dos Reis

There has been much interest recently in using the multi-species coalescent to estimate species phylogenies from molecular data. The advantage of the method is that incomplete lineage sorting (the discrepancy between gene trees and the species tree), and ancestral polymorphism are accounted for during phylogenetic inference. Bayesian implementations of the method are computationally expensive, and are best suited for inference among closely related species (or populations).

The figure below shows an example of a phylogeny of mouse lemurs (*Microcebus* spp.) estimated from RADseq (restriction site associated DNA sequencing) data using the program BPP (Yang, 2015), which implements the multi-species coalescent. Each node in the tree represents a speciation event, with the node ages given as numbers of substitutions per site. The blue bars represent the 95% credibility interval of the node age. For example, the molecular distance from the last common ancestor of *M. rufus* and *M. berthae* to the present is  $1.29 \times 10^{-4}$  substitutions per site. If we knew the molecular substitution rate per year for mouse lemurs, we could calibrate the tree to geological time, that is, we could convert the node ages from units of substitution per site to units of real time. I'll explain how to do so in this post.

## Article

# Evolution of the germline mutation rate across vertebrates

<https://doi.org/10.1038/s41586-023-05752-y>

Received: 19 November 2021

Accepted: 23 January 2023

Lucie A. Bergeron<sup>1</sup>✉, Søren Besenbacher<sup>2</sup>, Jiao Zheng<sup>3,4</sup>, Panyi Li<sup>3</sup>, Mads Frost Bertelsen<sup>5</sup>, Benoit Quintard<sup>6</sup>, Joseph I. Hoffman<sup>7,8</sup>, Zhipeng Li<sup>9</sup>, Judy St. Leger<sup>10</sup>, Changwei Shao<sup>11</sup>, Josefin Stiller<sup>1</sup>, M. Thomas P. Gilbert<sup>12,13</sup>, Mikkel H. Schierup<sup>14</sup> & Guojie Zhang<sup>1,15,16,17</sup>✉

“The authors have estimated the germline mutation rate in high-coverage genome sequences of 151 parent–offspring trios of 68 vertebrate species. This unique and impressive data set allowed the authors to perform a comparative analysis that has yielded insights into the evolution of the mutation rate and its association with diversity at the macroevolutionary level, and life-history traits across species that would not have been possible in previous smaller and more-fragmented data sets.”

Michelle Trenkmann, Senior Editor, Nature

# Basic logic of Pedigree Discovery of de novo mutations (DNMs)

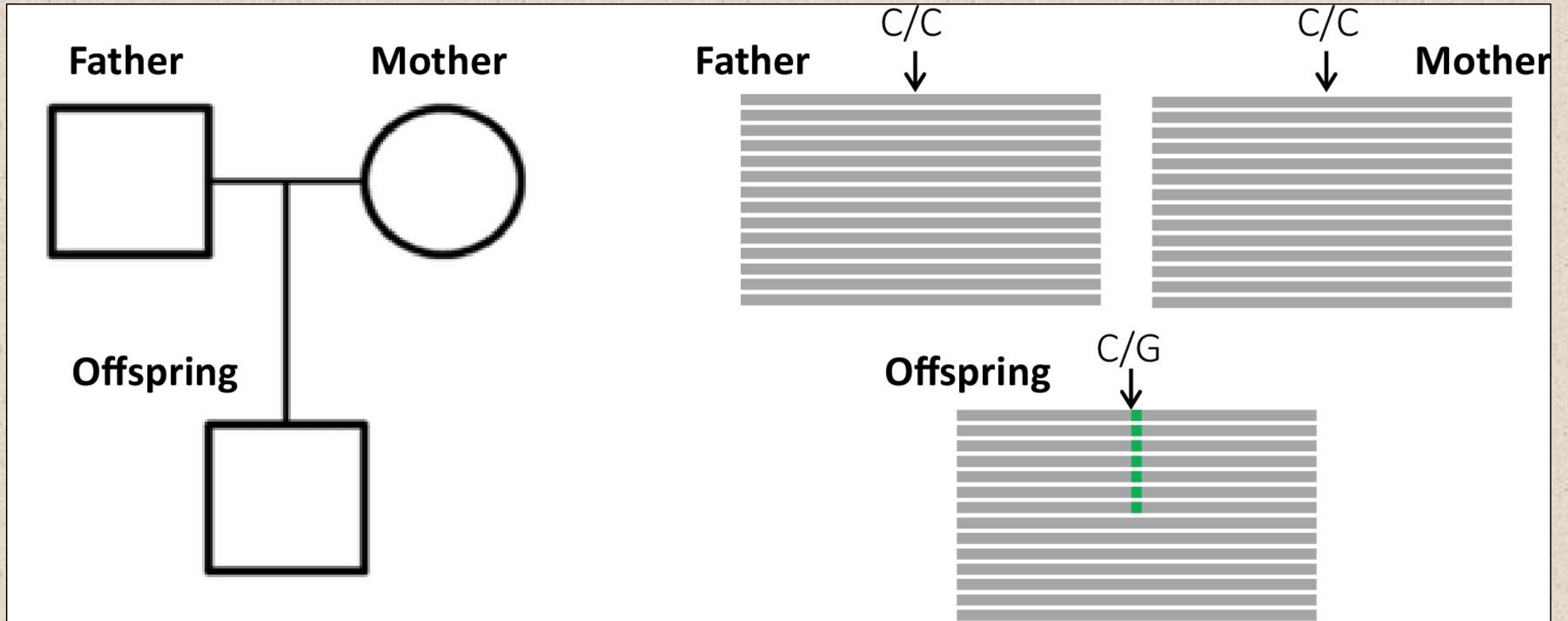

(figure from Bergeron et al., 2023)

# Computational Aspects of de novo mutation (DNMs) Discovery

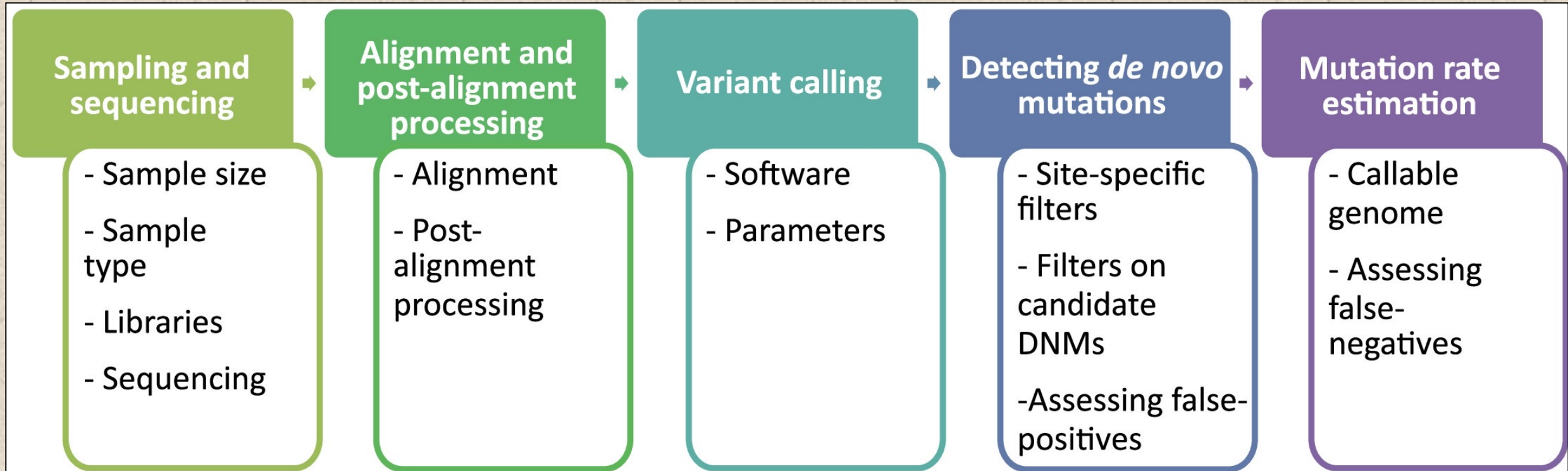



# Measuring de novo mutation rate:

- Count number of mutations
- Divide by size of the genome
- # mutations/size of genome = rate

Easy, right?

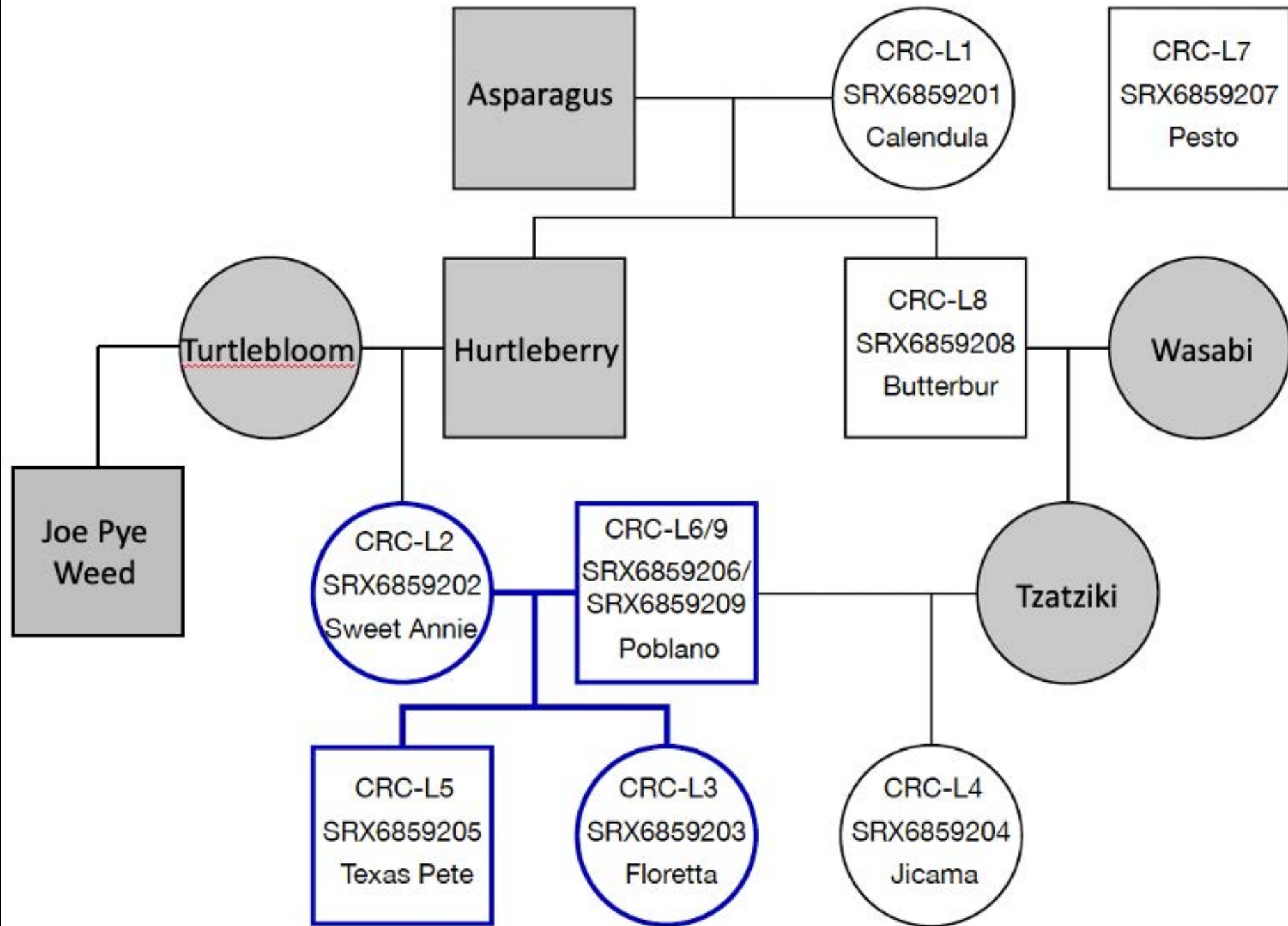

## Problems (just a few):

- Depth of coverage (some mutations will be called with more confidence than others)
- Genome assembly really, really matters (need long contigs to avoid, as much as possible, missing or misassembled regions due to highly repetitive regions)
- The number of “mutations” caused by sequencing error will VASTLY exceed biological mutations (replication errors)
- Ironically then, due to extreme filtering stringency the false negative rate can be just as error prone (if not more so) than the false positive rate

# Estimating the de novo mutation rate for the gray mouse lemur (*Microcebus murinus*)



C. Ryan Campbell

*the*  
**genetics**society

www.nature.com/hdy

## ARTICLE

Check for updates

Pedigree-based and phylogenetic methods support surprising patterns of mutation rate and spectrum in the gray mouse lemur

C. Ryan Campbell<sup>1,2,8</sup>, George P. Tiley <sup>1,8</sup>, Jelmer W. Poelstra<sup>1</sup>, Kelsie E. Hunnicutt <sup>1,6</sup>, Peter A. Larsen<sup>1,7</sup>, Hui-Jie Lee <sup>3</sup>, Jeffrey L. Thome<sup>4</sup>, Mario dos Reis <sup>5</sup> and Anne D. Yoder<sup>1,8</sup>

© The Author(s), under exclusive licence to The Genetics Society 2021

# Estimating mutation rate

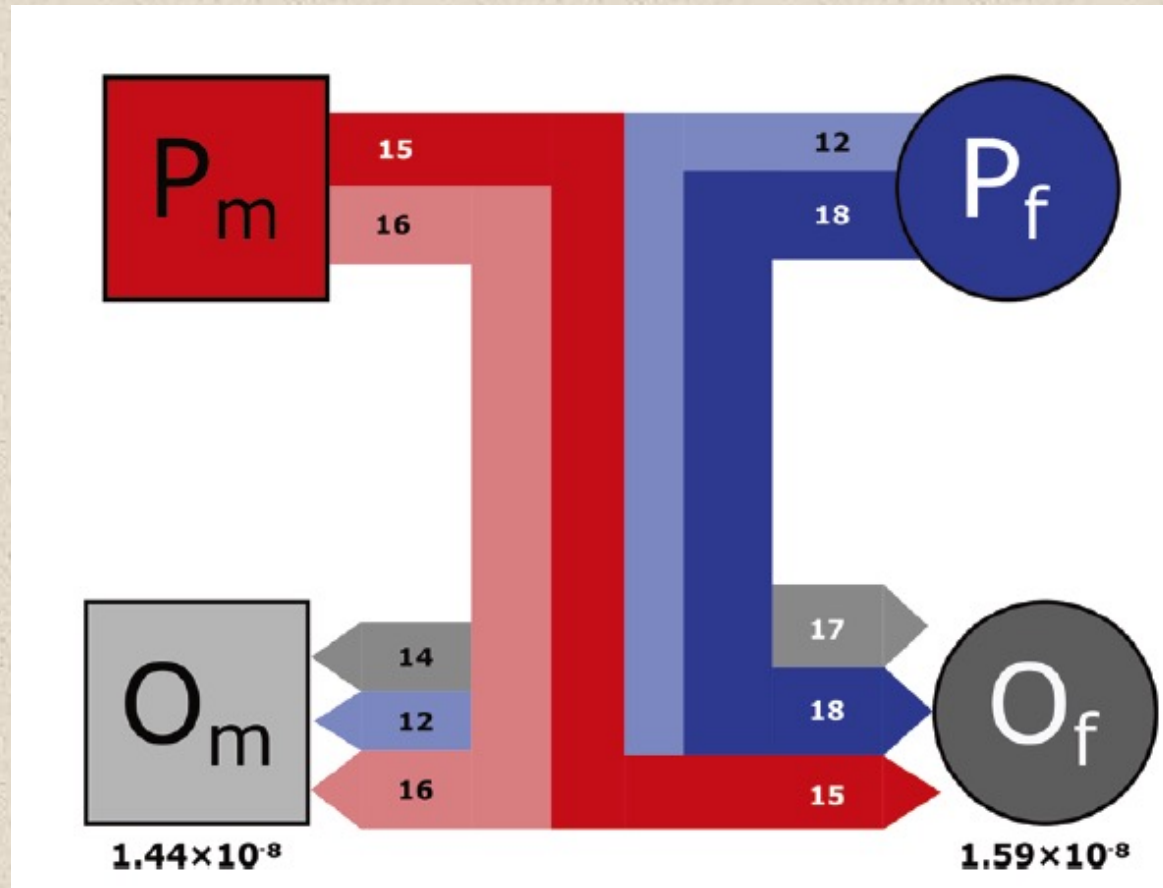

**“Trio” studies:** sequence the genomes of parents and their offspring, and “count” the mutations in offspring that are not observed in the parents.

2021





*the*  
**genetics**society

[www.nature.com/hdy](http://www.nature.com/hdy)

 Check for updates

## ARTICLE

De novo based and phylogenetic methods support surprising  
Rate is higher than expected and mutational spectrum surprising!  
patterns of mutation rate and spectrum in the gray mouse  
lemur

C. Ryan Campbell<sup>1,2,8</sup>, George P. Tiley <sup>1,8</sup>, Jelmer W. Poelstra<sup>1</sup>, Kelsie E. Hunnicutt <sup>1,6</sup>, Peter A. Larsen<sup>1,7</sup>, Hui-Jie Lee <sup>3</sup>,  
Jeffrey L. Thorne<sup>4</sup>, Mario dos Reis <sup>5</sup> and Anne D. Yoder<sup>1</sup> 

© The Author(s), under exclusive licence to The Genetics Society 2021

# Mouse Lemur Mutation Spectrum

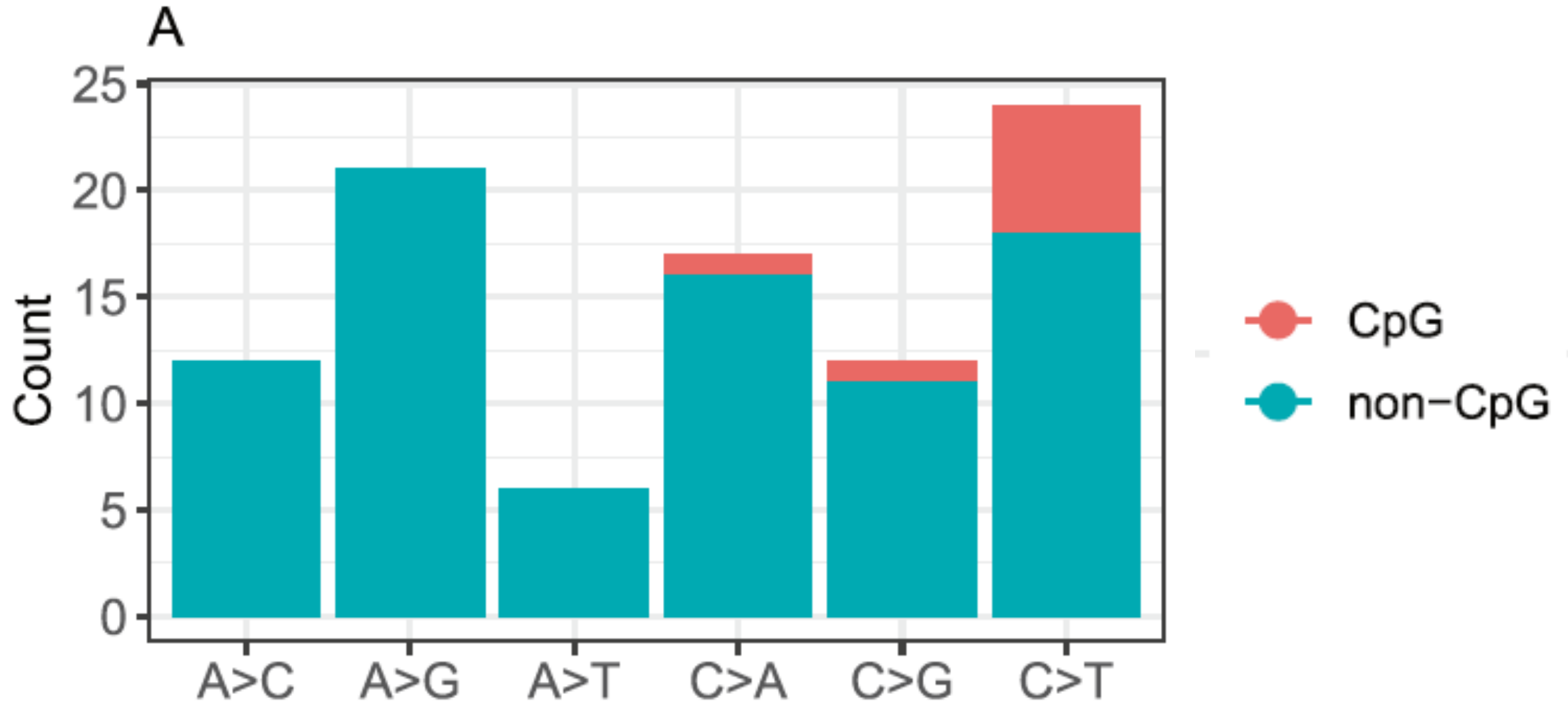

**Substitution rate analysis validates surprising results from a pedigree-based measurement of the de novo mutation rate in gray mouse lemurs.**

\*C. Ryan Campbell<sup>1,2</sup>, \*George P. Tiley<sup>1</sup>, Jelmer W. Poelstra<sup>1</sup>, Kelsie E. Hunnicutt<sup>1,†</sup>, Peter A. Larsen<sup>1,‡</sup>, Hui-Jie Lee<sup>3</sup>, Jeffrey L. Thorne<sup>4</sup>, Mario dos Reis<sup>5</sup>, Anne D. Yoder<sup>1</sup>

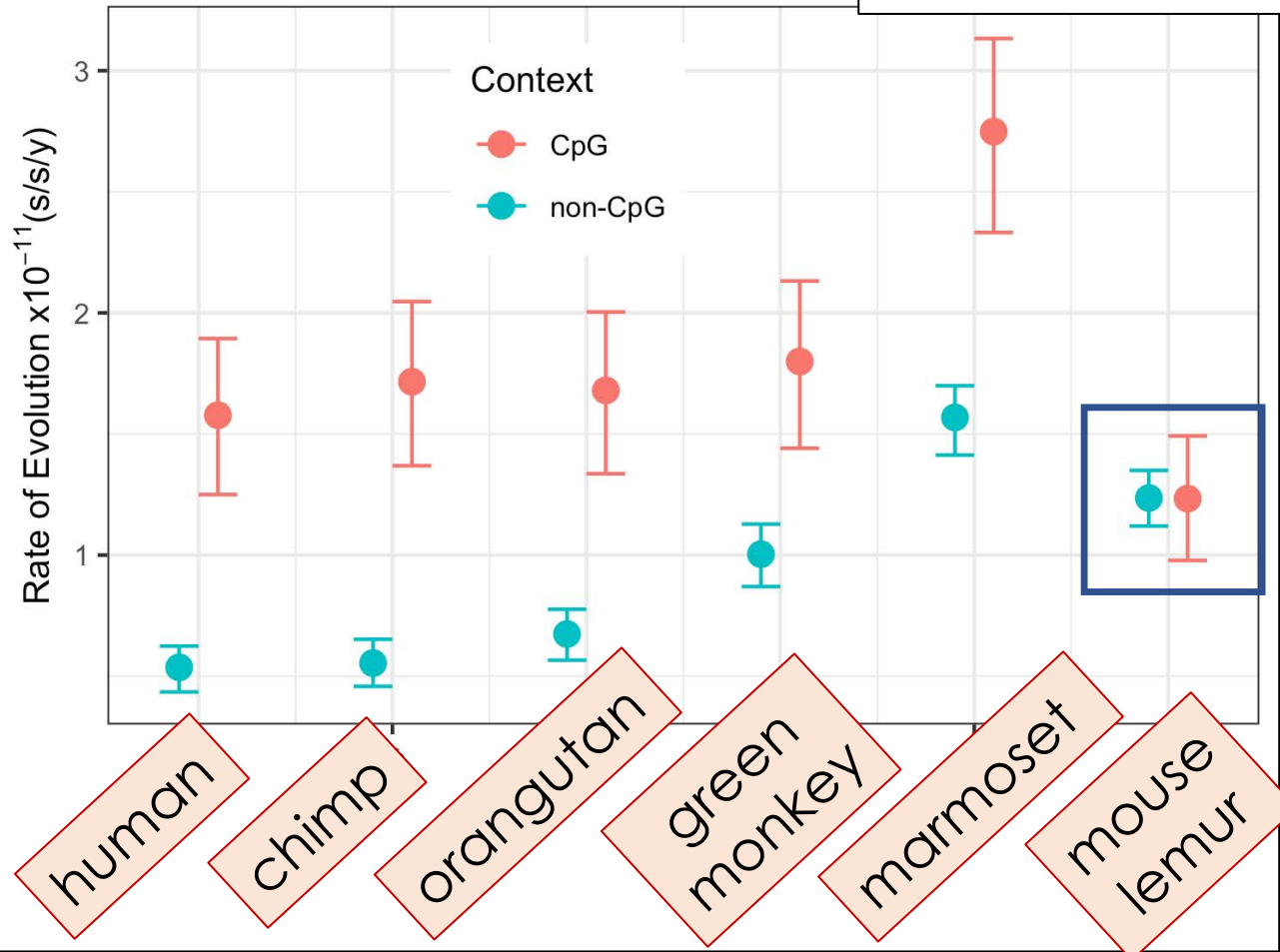

**Punch line:** substitution rate analysis yields same result regarding low values of CpG rate



# Key Findings

- High de novo rate – makes sense, right? 😎
- Low paternal bias – getting a little worrisome 🤔
- Very low CpG bias – biological nonsense? 😜



Even with sequencing accuracy of **99.9999%** you will have ~ 28,000 errors in 2.8 Gb genome ...

# Playing around with computational filters

					Callable Sites Filter								AB	
					Allele Drop	10x	11x	12x	15x	20x	22x	24x		25x
		PatMat Ratio	CpG Rate	de novo $\mu$	83.55%	88.46%	88.05%	87.55%	85.30%	77.27%	72.00%	65.52%	61.91%	
Allelic Balance Filter	None	1.11	8.41%	107	1.70E-08	1.60E-08	1.61E-08	1.62E-08	1.66E-08	1.84E-08	1.97E-08	2.17E-08	2.30E-08	
	20-80	1.11	8.41%	107	1.70E-08	1.60E-08	1.61E-08	1.62E-08	1.66E-08	1.84E-08	1.97E-08	2.17E-08	2.30E-08	
	25-75	1.11	8.41%	107	1.70E-08	1.60E-08	1.61E-08	1.62E-08	1.66E-08	1.84E-08	1.97E-08	2.17E-08	2.30E-08	
	25-65	1.06	8.57%	105	1.70E-08	1.59E-08	1.60E-08	1.61E-08	1.65E-08	1.83E-08	1.96E-08	2.15E-08	2.28E-08	
	30-70	1.03	8.70%	92	1.52E-08	1.43E-08	1.44E-08	1.44E-08	1.48E-08	1.64E-08	1.76E-08	1.93E-08	2.05E-08	
					Total Sites									

**Fig. 2 Effect of filtering thresholds on mutation-rate estimation.** The mutation rate and spectrum of the gray mouse lemur, as a product of two main filtering decisions: (1) an allelic balance filter (along the rows) and (2) a callable site filter (along the columns). The first three columns display how the parent-of-origin, the mutation rate at CpG sites, and total number of mutations vary. The remainder of the table shows the combined effect of these filters on the calculated rate. Cells for lower rates are shaded blue and higher rates are shaded red. All mutation rates have been corrected for the estimated number of false positives and false negatives with their respective number of mutations and callable sites.

# Playing around with computational filters

					Callable Sites Filter								AB	
					Allele Drop	10x	11x	12x	15x	20x	22x	24x		25x
		PatMat Ratio	CpG Rate	de novo $\mu$	83.55%	88.46%	88.05%	87.55%	85.30%	77.27%	72.00%	65.52%	61.91%	
Allelic Balance Filter	None	1.11	8.41%	107	1.70E-08	1.60E-08	1.61E-08	1.62E-08	1.66E-08	1.84E-08	1.97E-08	2.17E-08	2.30E-08	
	20-80	1.11	8.41%	107	1.70E-08	1.60E-08	1.61E-08	1.62E-08	1.66E-08	1.84E-08	1.97E-08	2.17E-08	2.30E-08	
	25-75	1.11	8.41%	107	1.70E-08	1.60E-08	1.61E-08	1.62E-08	1.66E-08	1.84E-08	1.97E-08	2.17E-08	2.30E-08	
	25-65	1.06	8.57%	105	1.70E-08	1.59E-08	1.60E-08	1.61E-08	1.65E-08	1.83E-08	1.96E-08	2.15E-08	2.28E-08	
	30-70	1.03	8.70%	92	1.52E-08	1.43E-08	1.44E-08	1.44E-08	1.48E-08	1.64E-08	1.76E-08	1.93E-08	2.05E-08	
Total Sites														

**Fig. 2 Effect of filtering thresholds on mutation-rate estimation.** The mutation rate and spectrum of the gray mouse lemur, as a product of two main filtering decisions: (1) an allelic balance filter (along the rows) and (2) a callable site filter (along the columns). The first three columns display how the parent-of-origin, the mutation rate at CpG sites, and total number of mutations vary. The remainder of the table shows the combined effect of these filters on the calculated rate. Cells for lower rates are shaded blue and higher rates are shaded red. All mutation rates have been corrected for the estimated number of false positives and false negatives with their respective number of mutations and callable sites.

Can have enormous impact on estimated rate

# Playing around with computational filters

					Callable Sites Filter									AB
					Allele Drop	10x	11x	12x	15x	20x	22x	24x	25x	
		PatMat Ratio	CpG Rate	de novo $\mu$	83.55%	88.46%	88.05%	87.55%	85.30%	77.27%	72.00%	65.52%	61.91%	
Allelic Balance Filter	None	1.11	8.41%	107	1.70E-08	1.60E-08	1.61E-08	1.62E-08	1.66E-08	1.84E-08	1.97E-08	2.17E-08	2.30E-08	
	20-80	1.11	8.41%	107	1.70E-08	1.60E-08	1.61E-08	1.62E-08	1.66E-08	1.84E-08	1.97E-08	2.17E-08	2.30E-08	
	25-75	1.11	8.41%	107	1.70E-08	1.60E-08	1.61E-08	1.62E-08	1.66E-08	1.84E-08	1.97E-08	2.17E-08	2.30E-08	
	25-65	1.06	8.57%	105	1.70E-08	1.59E-08	1.60E-08	1.61E-08	1.65E-08	1.83E-08	1.96E-08	2.15E-08	2.28E-08	
	30-70	1.03	8.70%	92	1.52E-08	1.43E-08	1.44E-08	1.44E-08	1.48E-08	1.64E-08	1.76E-08	1.93E-08	2.05E-08	
					Total Sites									

**Fig. 2 Effect of filtering thresholds on mutation-rate estimation.** The mutation rate and spectrum of the gray mouse lemur, as a product of two main filtering decisions: (1) an allelic balance filter (along the rows) and (2) a callable site filter (along the columns). The first three columns display how the parent-of-origin, the mutation rate at CpG sites, and total number of mutations vary. The remainder of the table shows the combined effect of these filters on the calculated rate. Cells for lower rates are shaded blue and higher rates are shaded red. All mutation rates have been corrected for the estimated number of false positives and false negatives with their respective number of mutations and callable sites.

Has little impact on estimate of mutational spectrum

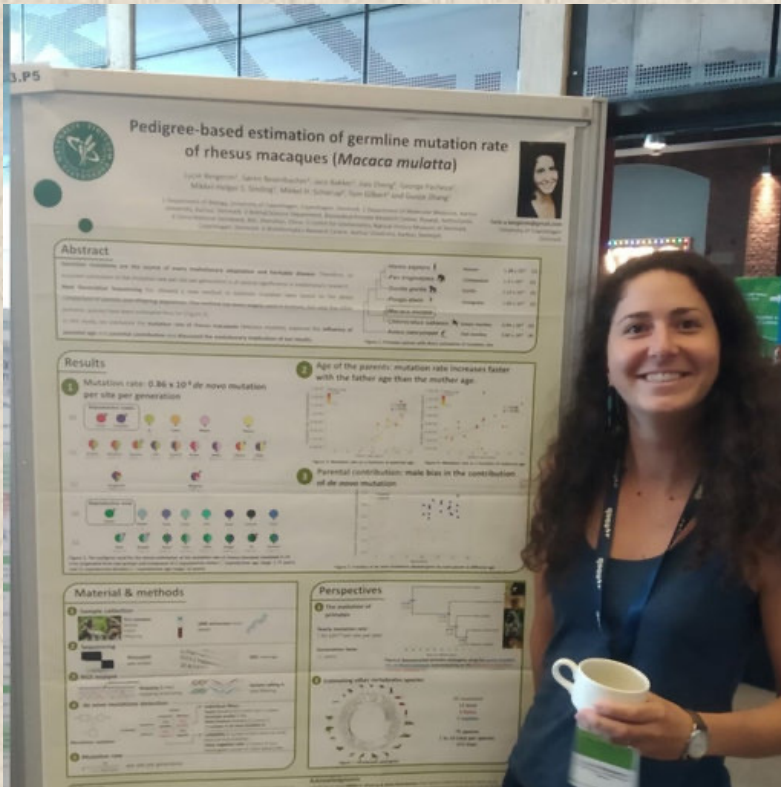

# Working towards best practices: standardize methods so that results are comparable!



Lucie Bergeron



TOOLS AND RESOURCES



## The Mutationathon highlights the importance of reaching standardization in estimates of pedigree-based germline mutation rates

Lucie A Bergeron<sup>1\*</sup>, Søren Besenbacher<sup>2</sup>, Tychele Turner<sup>3</sup>, Cyril J Versoza<sup>4</sup>, Richard J Wang<sup>5</sup>, Alivia Lee Price<sup>1</sup>, Ellie Armstrong<sup>6</sup>, Meritxell Riera<sup>7</sup>, Jedidiah Carlson<sup>8</sup>, Hwei-yen Chen<sup>1</sup>, Matthew W Hahn<sup>5</sup>, Kelley Harris<sup>8</sup>, April Snøfrid Kleppe<sup>2</sup>, Elora H López-Nandam<sup>9</sup>, Priya Moorjani<sup>10</sup>, Susanne P Pfeifer<sup>11</sup>, George P Tiley<sup>12</sup>, Anne D Yoder<sup>12</sup>, Guojie Zhang<sup>1</sup>, Mikkel H Schierup<sup>7\*</sup>

“We report **almost a two-fold variation** in the final estimated rate among groups using different post-alignment processing, calling, and filtering criteria and provide details into the sources of variation across studies.”



Evan Eichler

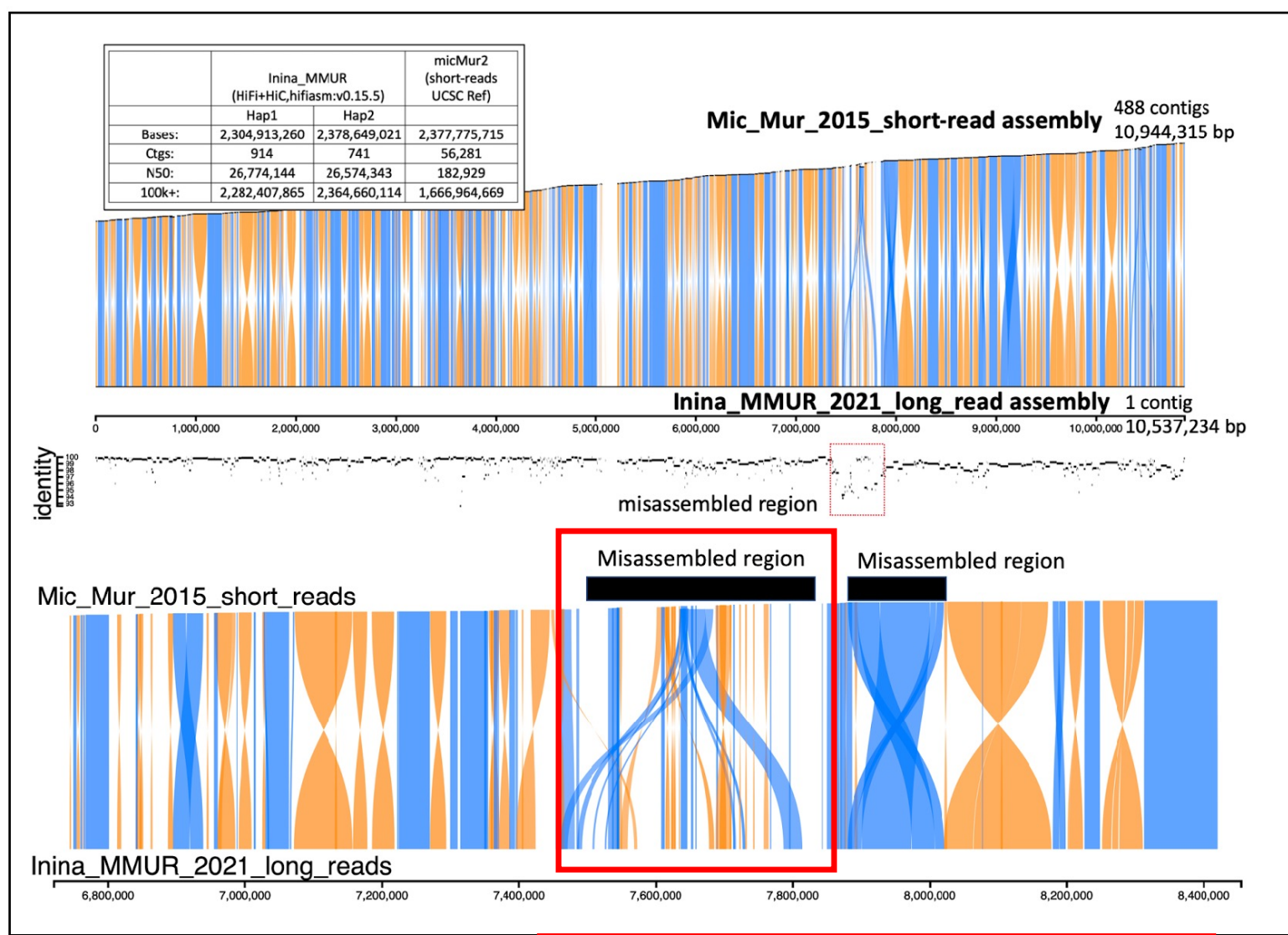

**Figure 3.** Comparison of applicant Eichler's new **T2T long-read mouse lemur assembly vs current ref. genome.** Top panel: A single contig of 10.5 Mbp from HiFiasm assembly (*inina\_MMUR*) of a mouse lemur (*Microcebus murinus*) is compared to the current reference on UCSC (*Mic\_Mur*) which consists of 488 contigs where orientation is often in error. Each break in reference where there is an orientation flip is colored (blue/orange) while missing sequence is depicted (white space). QV accuracy for the long-read is estimated at >45, however, alignment to the existing reference identifies regions of reduced identity (red dashed box) corresponding most likely to low quality and/or misassembled regions in the current reference. Bottom panel: expanded view of red box showing multiple assembly errors and breaks in the existing reference making it virtually useless for DNM detection.



◆ Hypothesized DNM transmissions □ Transmission validation (~50% heritability)

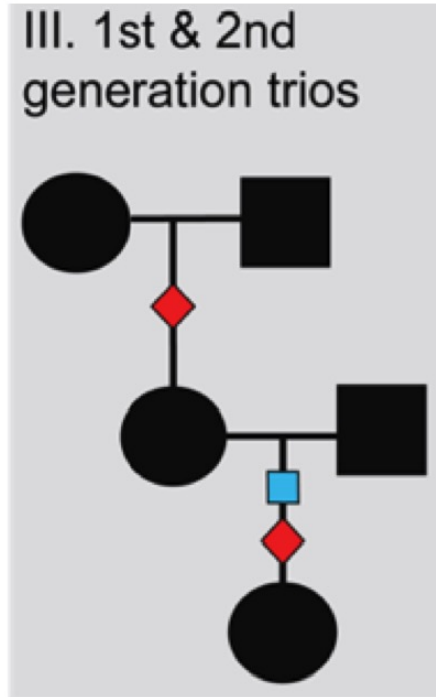
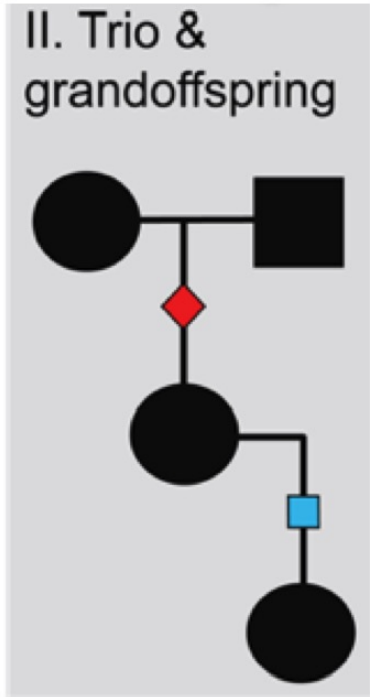
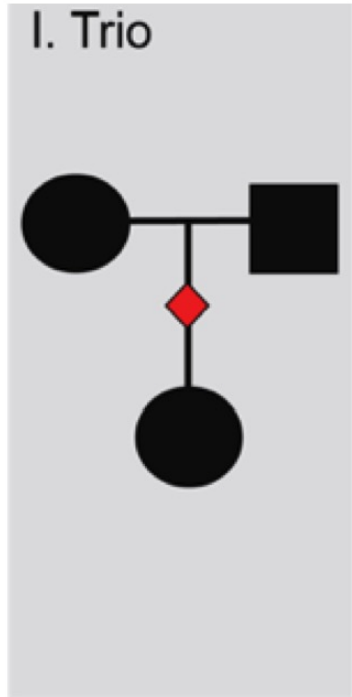

**FATHER:**  
 ATTCGGCTTCGATCATTTCATTCATGCTTCGATCTCGAAAATT  
 ATTCGGCTTCGATCATTTCATTCATGCTTCGATCTCGAAAATT  
 ATTCGGCTTCGATCATTTCATTCATGCTTCGATCTCGAAAATT  
 ATTCGGCTTCGATCATTTCATTCATGCTTCGATCTCGAAAATT  
 ATTCGGCTTCGATCATTTCATTCATGCTTCGATCTCGAAAATT  
 ATTCGGCTTCGATCATTTCATTCATGCTTCGATCTCGAAAATT

**MOTHER:**  
 ATTCGGCTTCGATCATTTCATTCATGCTTCGATCTCGAAAATT  
 ATTCGGCTTCGATCATTTCATTCATGCTTCGATCTCGAAAATT  
 ATTCGGCTTCGATCATTTCATTCATGCTTCGATCTCGAAAATT  
 ATTCGGCTTCGATCATTTCATTCATGCTTCGATCTCGAAAATT  
 ATTCGGCTTCGATCATTTCATTCATGCTTCGATCTCGAAAATT  
 ATTCGGCTTCGATCATTTCATTCATGCTTCGATCTCGAAAATT

**OFFSPRING:**  
 ATTCGGCTTCGATCATTTCATTCATGCTTCGATCTCGAAAATT  
 ATTCGGCTTCGATCATTTCATTCATGCTTCGATCTCGAAAATT  
 ATTCGGCTTCGATCATTTCATTCATGCTTCGATCTCGAAAATT  
 ATTCGGCTTCGATCATTTCATTCATGCTTCGATCTCGAAAATT  
 ATTCGGCTTCGATCATTTCATTCATGCTTCGATCTCGAAAATT  
 ATTCGGCTTCGATCATTTCATTCATGCTTCGATCTCGAAAATT

**Figure 1.** In the trio design (I), parent and offspring genomes are sequenced, reads aligned to a reference genome, and variants called. Distinguishing DNMs (T nucleotide shown in red, far right) from somatic mutations and sequencing errors requires checking the allele balance is 0.5 across sequencing reads, as DNMs are inherited from one of the parents and thus DNM sites are heterozygous. Including a second generation in the pedigree (II and III) improves variant calling as half of DNMs in the F1 must be transmitted to the F2, helping reduce the false positive rate. Red diamonds indicate identifiable DNM transmissions, and blue squares indicate DNM transmission validations.

**Complexities of calculating  
generation times (a few) ...**

# Estimating generation times:

## Key parameters

- Age at onset of first offspring to last reproductive event
- Number of offspring produced from first to last reproduction
- Probability of surviving to age of last reproduction

# Stable, high-quality environments

- Low mortality (oldest old ~ 8 years)
- Breed at age = 1 year
- Only one litter per year





## Low-quality, unpredictable environments

- High mortality (oldest old ~ 3 years)
- Breed very early ( $\leq$  four months)
- Multiple litters per year (i.e., overlapping generations within a single year)





These behaviors have a complex relationship with the capacity for torpor in mouse lemurs; they can undergo a “**metabolic switch**” that leads to fattening and prolonged torpor/hibernation ... seems to be highly flexible by species and environment



Review

# Molecular Clocks without Rocks: New Solutions for Old Problems

George P. Tiley <sup>1</sup>, Jelmer W. Poelstra,<sup>1</sup> Mario dos Reis,<sup>2</sup> Ziheng Yang <sup>3</sup> and Anne D. Yoder<sup>1,\*</sup>



MRCA = 8 – 10 Ma  
(concatenation)

MRCA ~ 1.5 Ma  
(MSC)

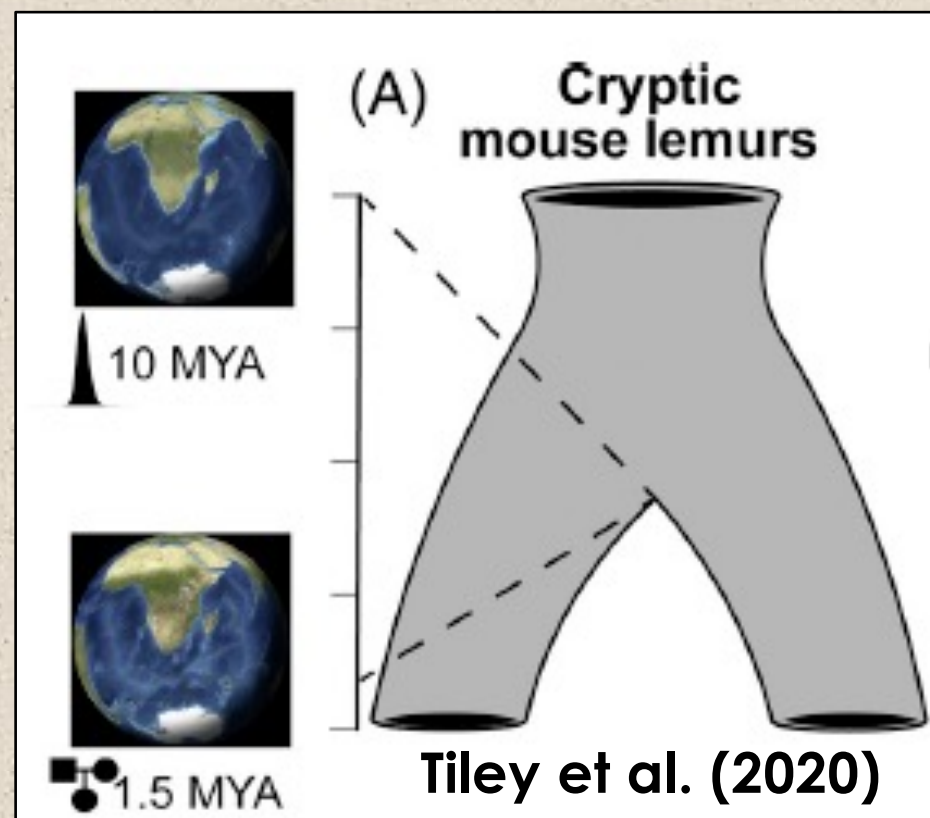

**You might now be pretty freaked out:  
Let's take a break!**



## Back to speciation: three case studies:

1. Intraspecific divergence driven by natural climate change (**incipient?**)
2. Lineage diversification in close geographic proximity (**ongoing?**)
3. Reproductive isolation in sympatry (**complete?**)

# Story # 1



COLLOQUIUM  
PAPER

## Geogenetic patterns in mouse lemurs (genus *Microcebus*) reveal the ghosts of Madagascar's forests past

Anne D. Yoder<sup>a,b,1</sup>, C. Ryan Campbell<sup>a</sup>, Marina B. Blanco<sup>b</sup>, Mario dos Reis<sup>c</sup>, Jörg U. Ganzhorn<sup>d</sup>, Steven M. Goodman<sup>e,f</sup>, Kelsie E. Hunnicutt<sup>a</sup>, Peter A. Larsen<sup>a</sup>, Peter M. Kappeler<sup>g</sup>, Rodin M. Rasoloarison<sup>g,h</sup>, José M. Ralison<sup>h</sup>, David L. Swofford<sup>a</sup>, and David W. Weisrock<sup>i</sup>

<sup>a</sup>Department of Biology, Duke University, Durham, NC 27708; <sup>b</sup>Duke Lemur Center, Duke University, Durham, NC 27705; <sup>c</sup>School of Biological and Chemical Sciences, Queen Mary University of London, London E1 4NS, United Kingdom; <sup>d</sup>Tierökologie und Naturschutz, Universität Hamburg, 20146 Hamburg, Germany; <sup>e</sup>Field Museum of Natural History, Chicago, IL 60605; <sup>f</sup>Association Vahatra, BP 3972, Antananarivo 101, Madagascar; <sup>g</sup>Behavioral Ecology and Sociobiology Unit, German Primate Centre, 37077 Goettingen, Germany; <sup>h</sup>Département de Biologie Animale, Université d'Antananarivo, BP 906, Antananarivo 101, Madagascar; and <sup>i</sup>Department of Biology, University of Kentucky, Lexington, KY 40506

PNAS

# Mouse lemur sampling (TCI grant)



5 field sites  
29 mouse lemurs  
7 dwarf lemurs  
4 flights  
4200Km by road



Slide courtesy of Marina Blanco





370 mi

Data SIO, NOAA, U.S. Navy, NGA, GEBCO  
Image Landsat

Google earth



“Geogenetic patterns” indicate that there were forest “bridges” across Madagascar that must have entirely disappeared by ~ 50K ybp

Yoder et al., 2016

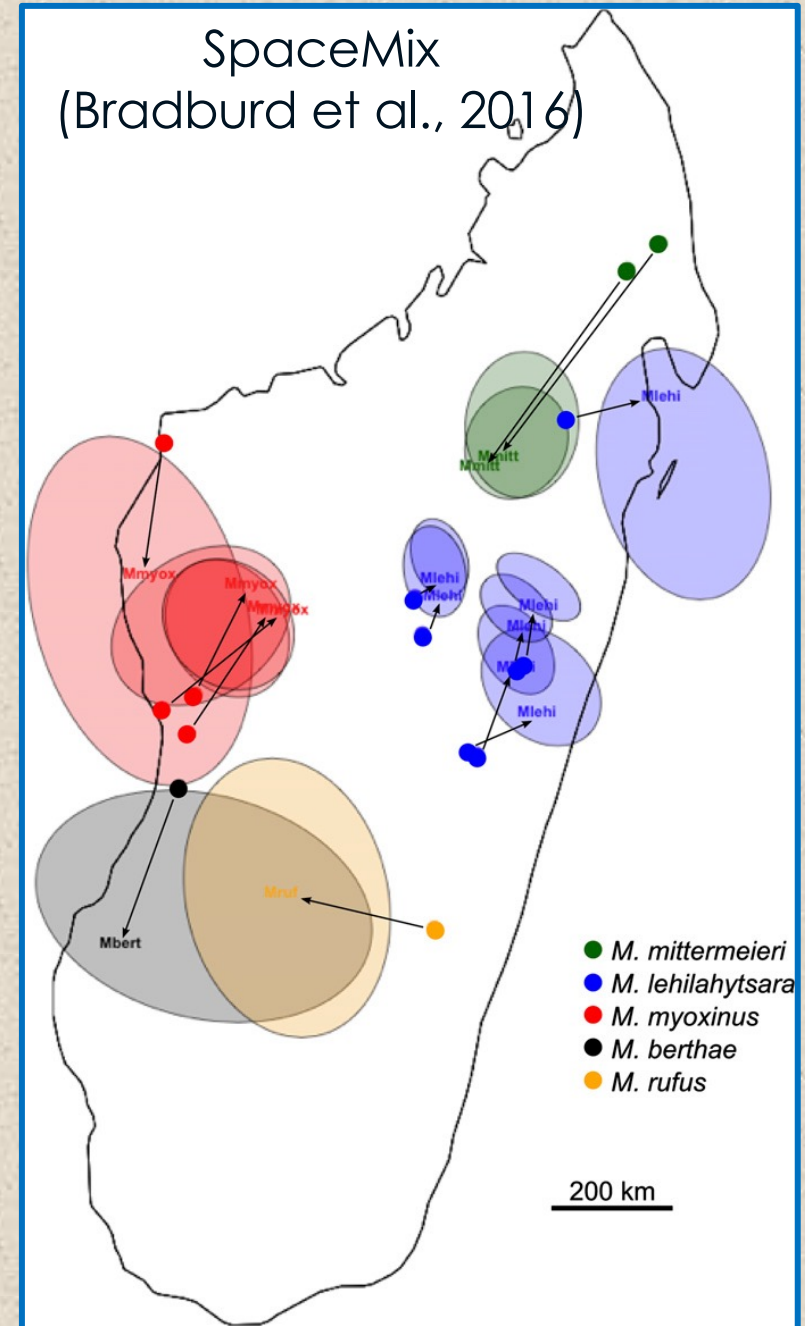



*Microcebus berthae*





*Microcebus rufus*

# *berthae-myoxinus-rufus*

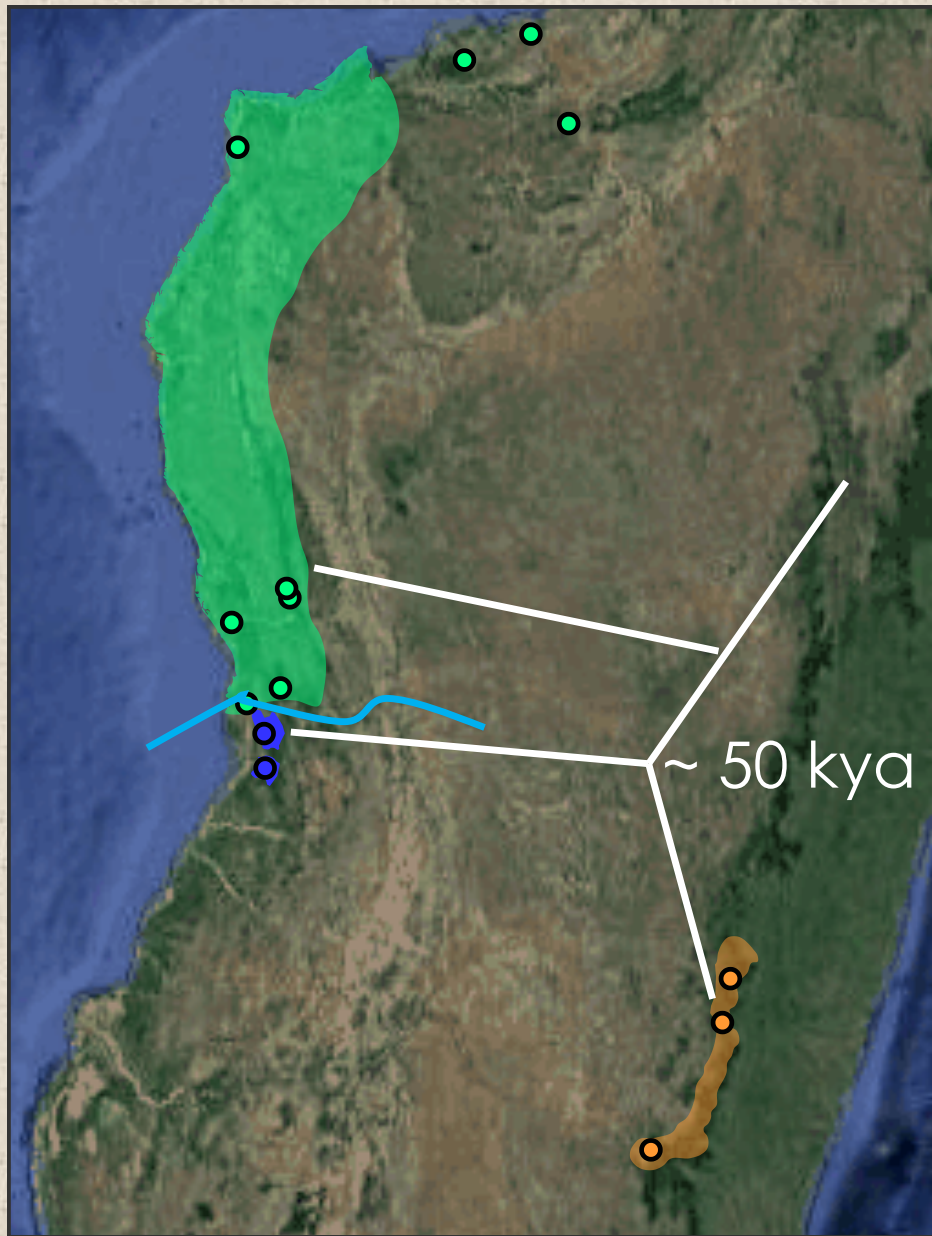

species

- berthae
- myoxinus
- rufus



Adult Body  
Weight = **30**  
grams!



# Geogenetic patterns in mouse lemurs (genus *Microcebus*) reveal the ghosts of Madagascar's forests past

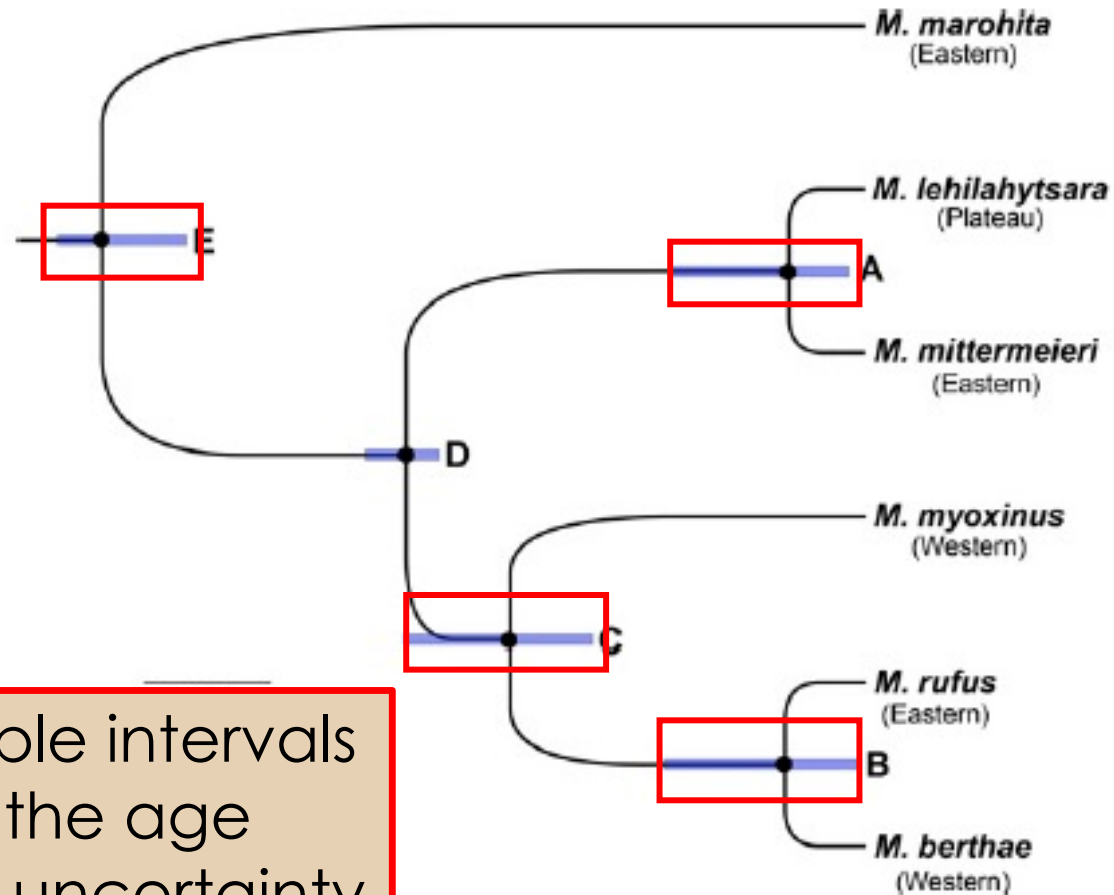

Wide credible intervals around the age estimates = uncertainty

# Using directly estimated mutation rate has a big impact on estimated divergence times ...

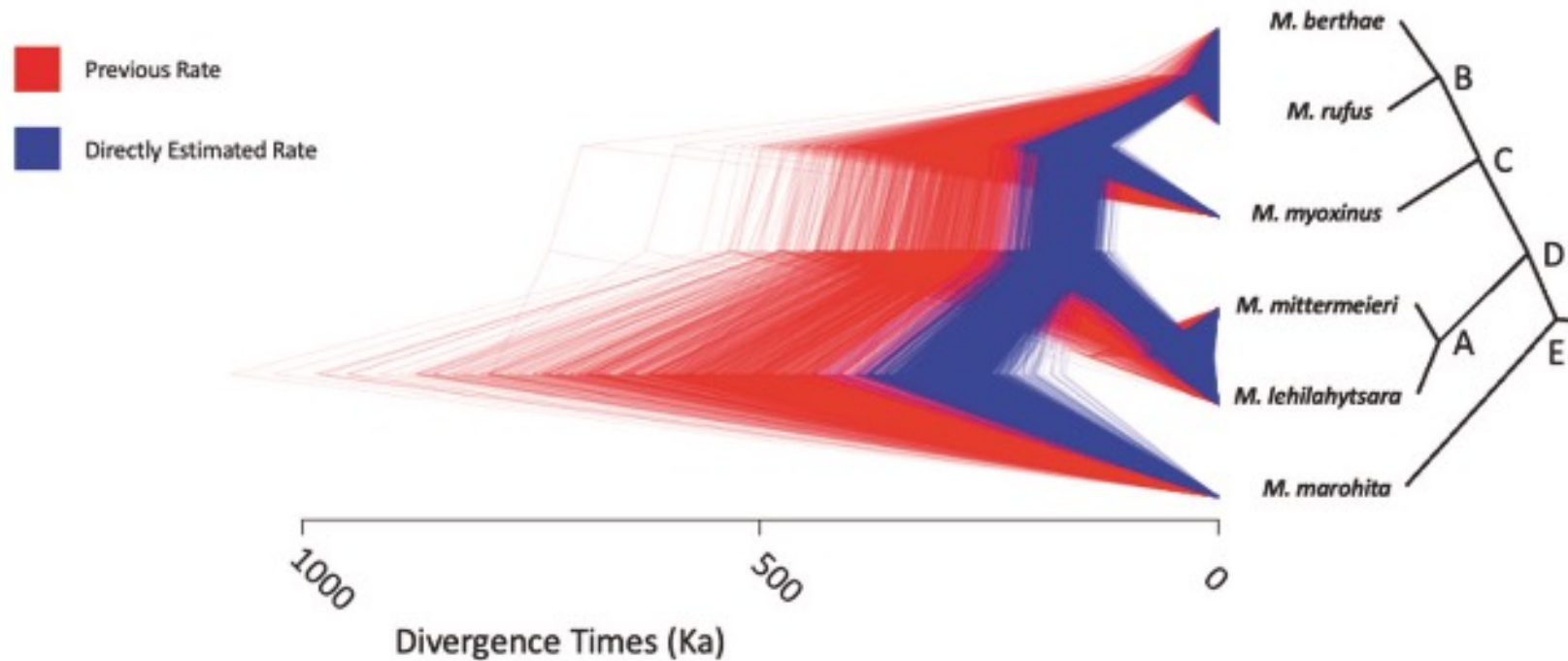

**Fig. 6 Estimated divergence times among mouse lemur species.** Trees are posterior samples from BPP based on a fixed previously published topology. The directly estimated mutation rate (blue) is nearly twice as high as the previously assumed rate (red). Divergence times estimated with the new mutation rate are nearly half of the previous estimates. Summary statistics are given in Table S4, matched by node labels (A–E).

## Summary of Story 1:

- Forest fragments that are believed to be anthropogenic may actually be “museums” of genetic diversity
- The Central Plateau of Madagascar may have long been characterized by mixed savannah and woodlands
- Either way, there must have been forest corridors across the island as recently as 50 kya that no longer exist
- Rivers appear to be potent biogeographic barriers (at least, for mouse lemurs)

# Follow-up study: Intraspecific divergence driven by natural climate change? (Goodman's mouse lemur, *M. lehilahytsara*)

Received: 19 September 2020

Revised: 25 June 2022

Accepted: 8 July 2022

DOI: 10.1111/mec.16632

ORIGINAL ARTICLE

MOLECULAR ECOLOGY WILEY

## Population genomic structure in Goodman's mouse lemur reveals long-standing separation of Madagascar's Central Highlands and eastern rainforests

George P. Tiley<sup>1</sup>  | Tobias van Elst<sup>2</sup>  | Helena Teixeira<sup>2</sup> | Dominik Schübler<sup>3</sup>  |  
Jordi Salmons<sup>4</sup>  | Marina B. Blanco<sup>5</sup> | José M. Ralison<sup>6</sup> |  
Blanchard Randrianambinina<sup>7,8</sup> | Rodin M. Rasoloarison<sup>6,7,9</sup> | Amanda R. Stahlke<sup>10</sup>  |  
Paul A. Hohenlohe<sup>10</sup>  | Lounès Chikhi<sup>4,11</sup>  | Edward E. Louis<sup>12</sup> | Ute Radespiel<sup>2</sup>  |  
Anne D. Yoder<sup>1</sup> 



George Tiley

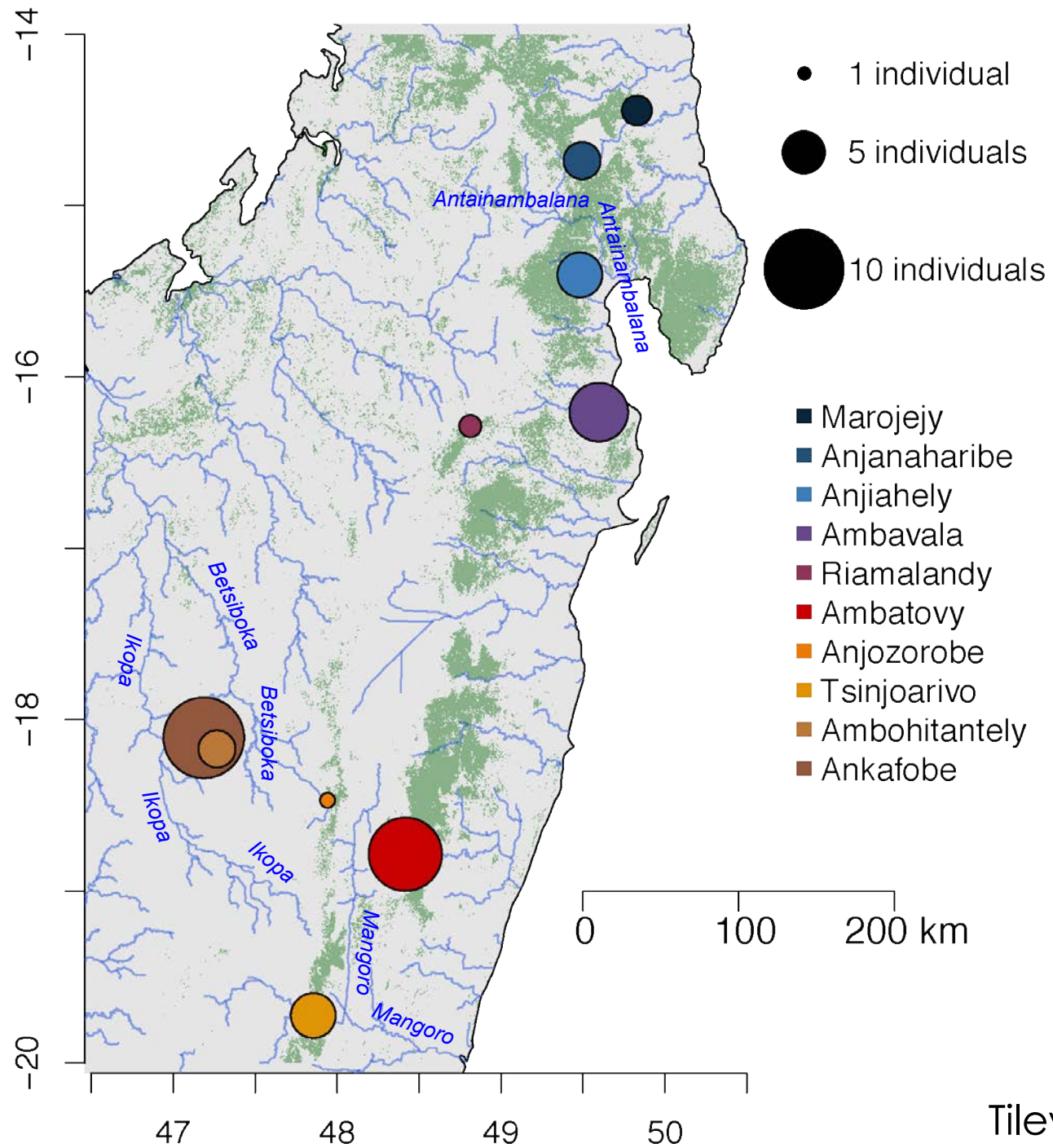

# Increased geographic sampling confirms previous results: LOTS of population structure congruent with grassland hypothesis

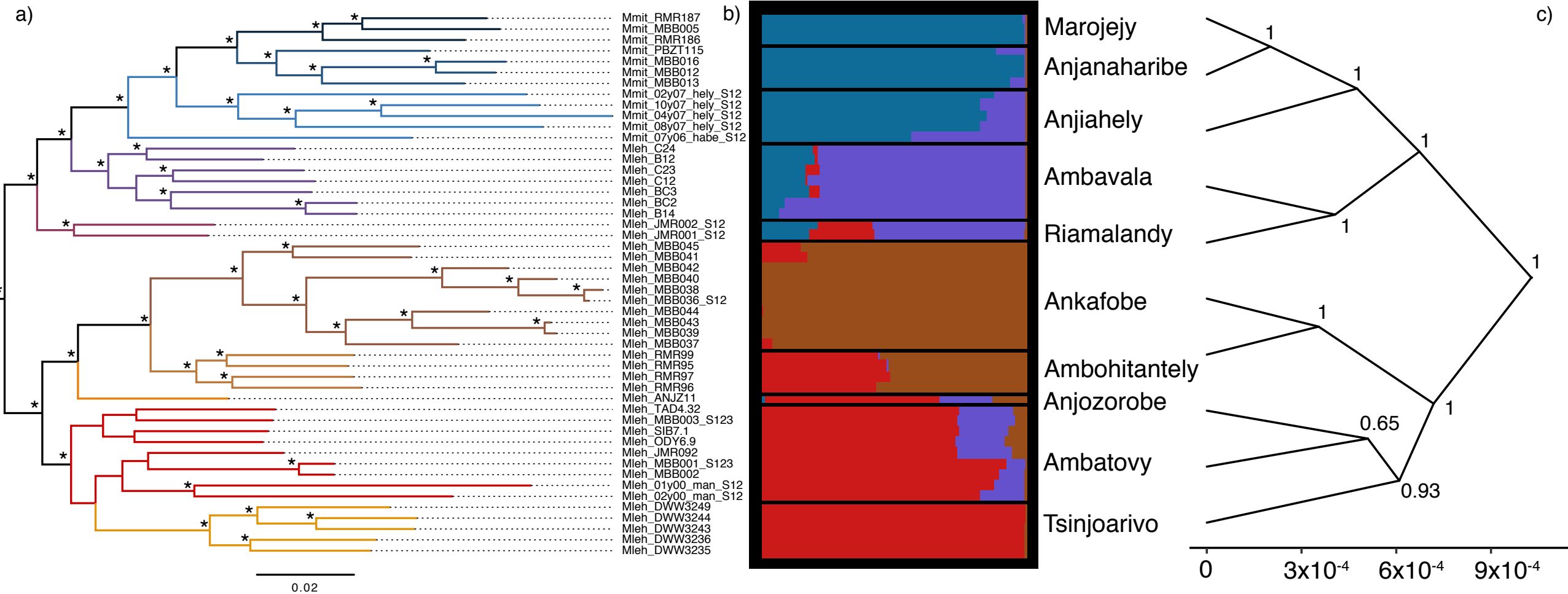



PSMC analysis shows TWO episodes of population crash: One congruent with LGM and a second one congruent with human arrival

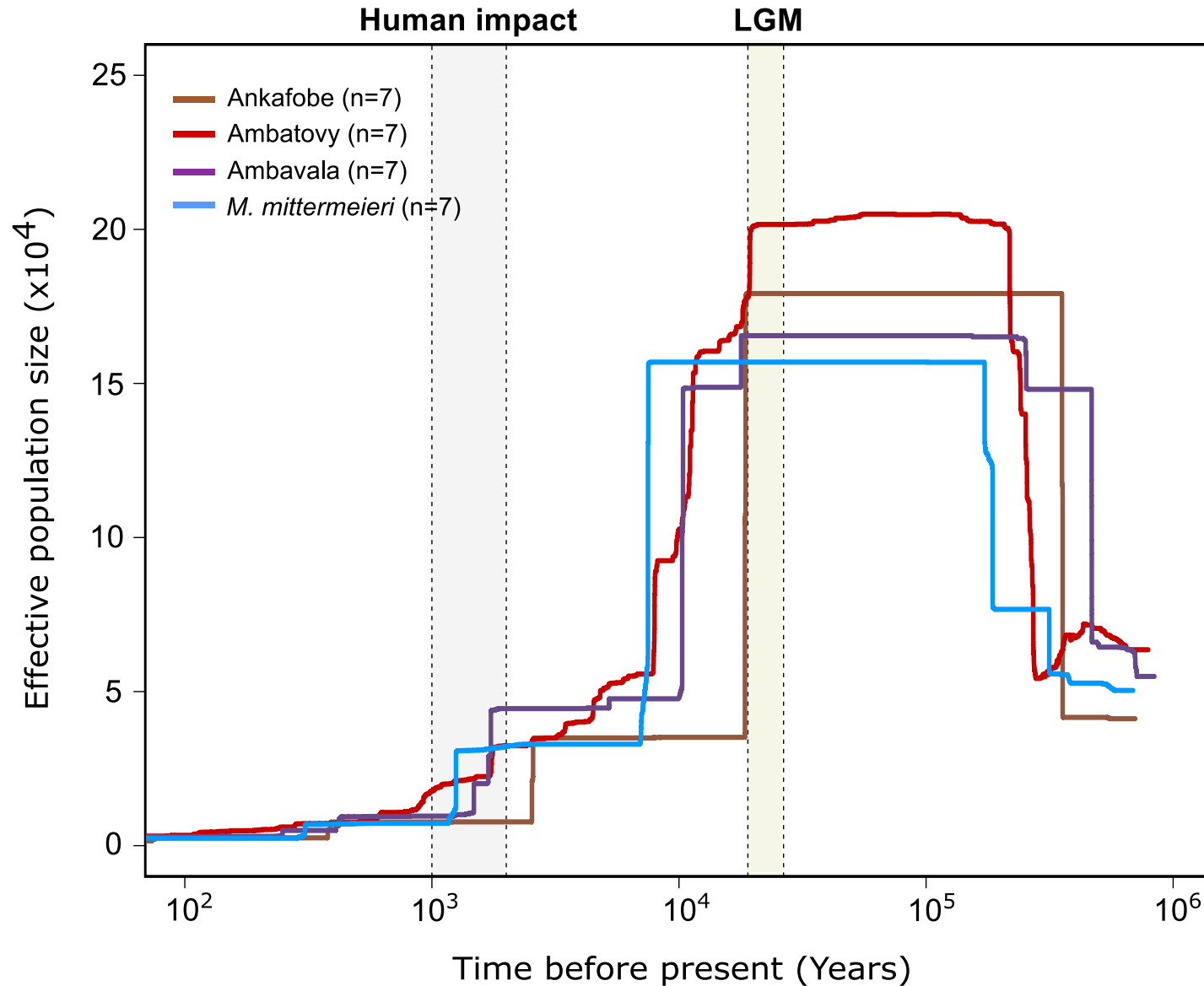

# Story # 2

*Syst. Biol.* 70(2):203–218, 2021

© The Author(s) 2020. Published by Oxford University Press, on behalf of the Society of Systematic Biologists. All rights reserved.

For permissions, please email: journals.permissions@oup.com

DOI:10.1093/sysbio/syaa053

Advance Access publication July 8, 2020

## Cryptic Patterns of Speciation in Cryptic Primates: Microendemic Mouse Lemurs and the Multispecies Coalescent

JELMER W. POELSTRA<sup>1</sup>, JORDI SALMONA<sup>2</sup>, GEORGE P. TILEY<sup>1</sup>, DOMINIK SCHÜBLER<sup>3</sup>, MARINA B. BLANCO<sup>1,4</sup>, JEAN B. ANDRIAMBELOSON<sup>5</sup>, OLIVIER BOUCHEZ<sup>6</sup>, C. RYAN CAMPBELL<sup>1,7</sup>, PAUL D. ETTER<sup>8</sup>, PAUL A. HOHENLOHE<sup>9</sup>, KELSIE E. HUNNICUTT<sup>1,10</sup>, AMAIA IRIBAR<sup>2</sup>, ERIC A. JOHNSON<sup>8</sup>, PETER M. KAPPELER<sup>11</sup>, PETER A. LARSEN<sup>1,12</sup>, SOPHIE MANZI<sup>2</sup>, JOSÉ M. RALISON<sup>5</sup>, BLANCHARD RANDRIANAMBININA<sup>13,14</sup>, RODIN M. RASOLOARISON<sup>11</sup>, DAVID W. RASOLOFOSON<sup>13</sup>, AMANDA R. STAHLKE<sup>9</sup>, DAVID W. WEISROCK<sup>15</sup>, RACHEL C. WILLIAMS<sup>1,4</sup>, LOUNÈS CHIKHI<sup>2,16</sup>, EDWARD E. LOUIS JR.<sup>17</sup>, UTE RADESPIEL<sup>18,\*</sup>, AND ANNE D. YODER<sup>1,\*</sup>

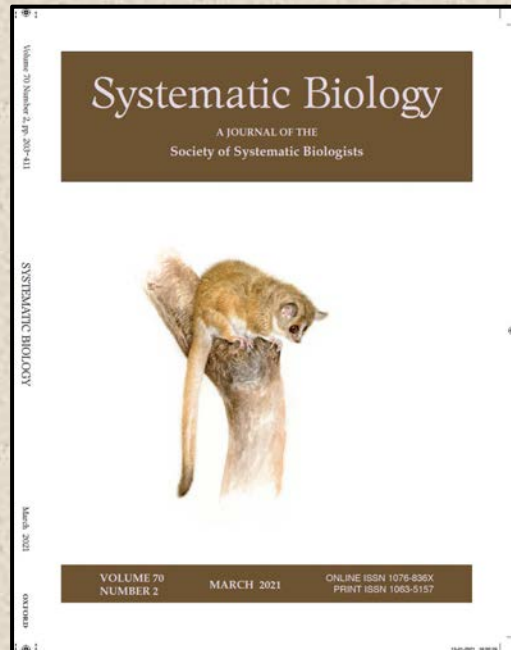

Jelmer Poelstra

Five metapopulation lineages appear to be independently evolving in small geographic area

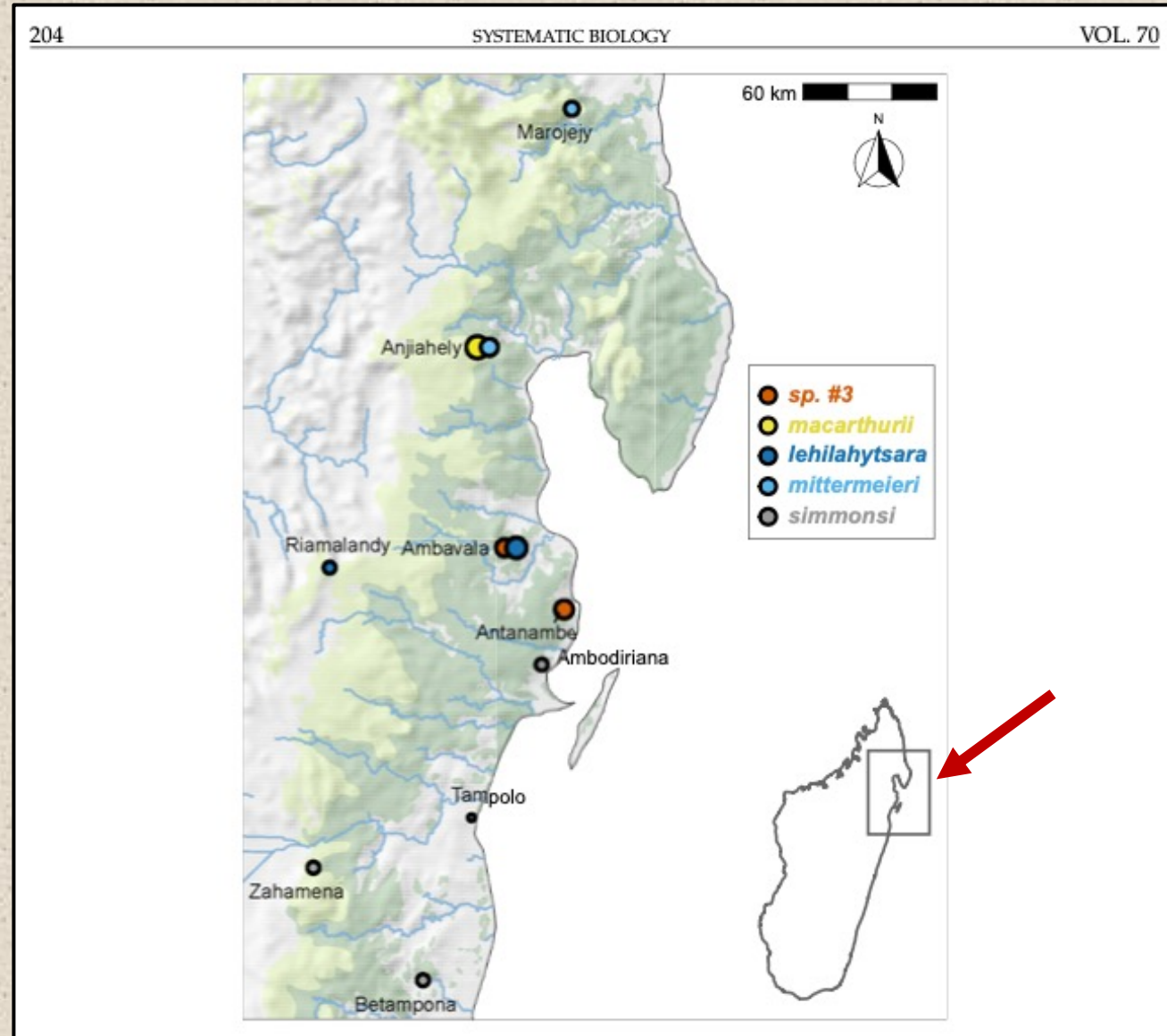

# Phylogenetic analysis of RADseq data revealed brand-new unnamed lineage

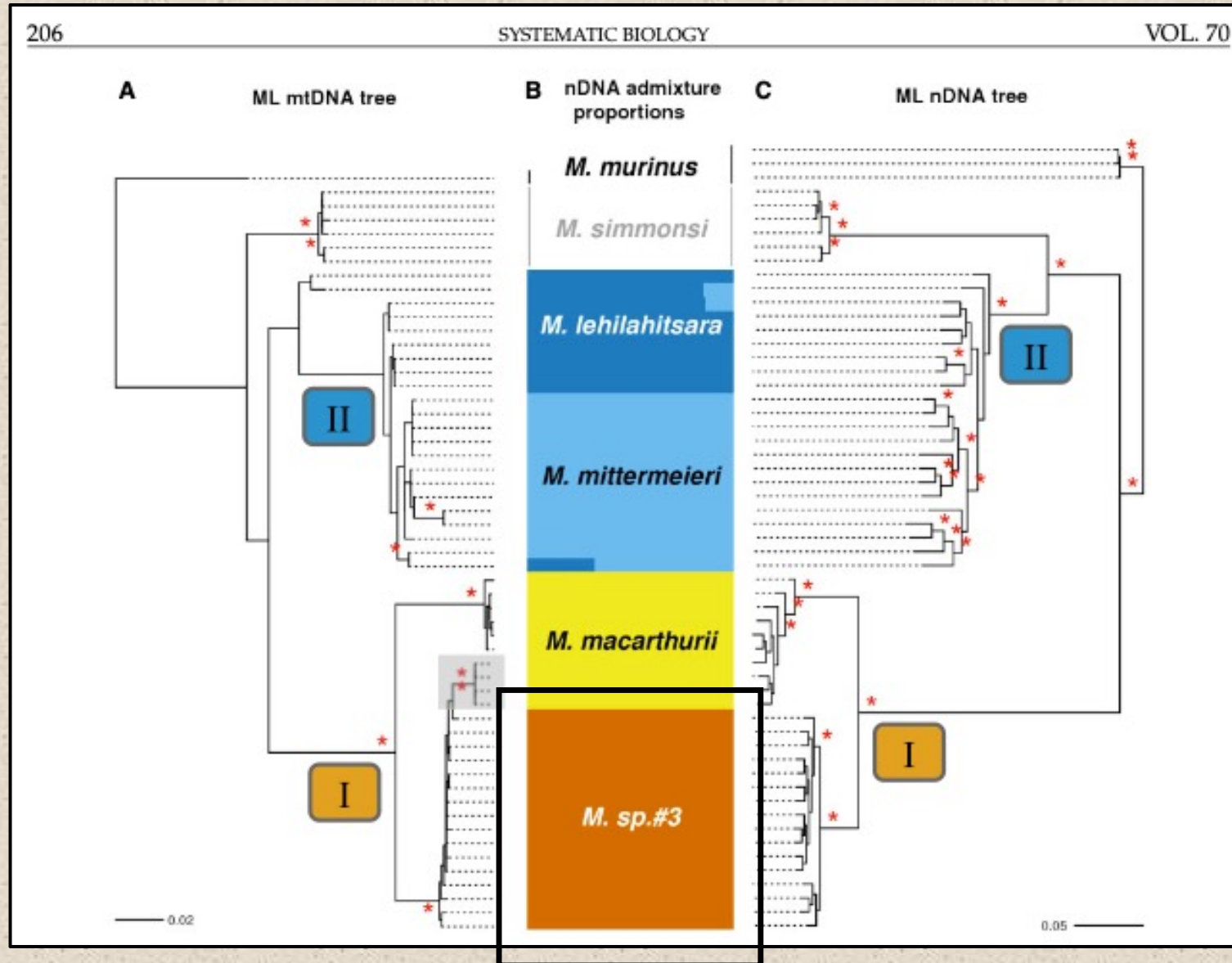

# Two areas of sympatric co-occurrence:

C) All 6 lineages K = 6

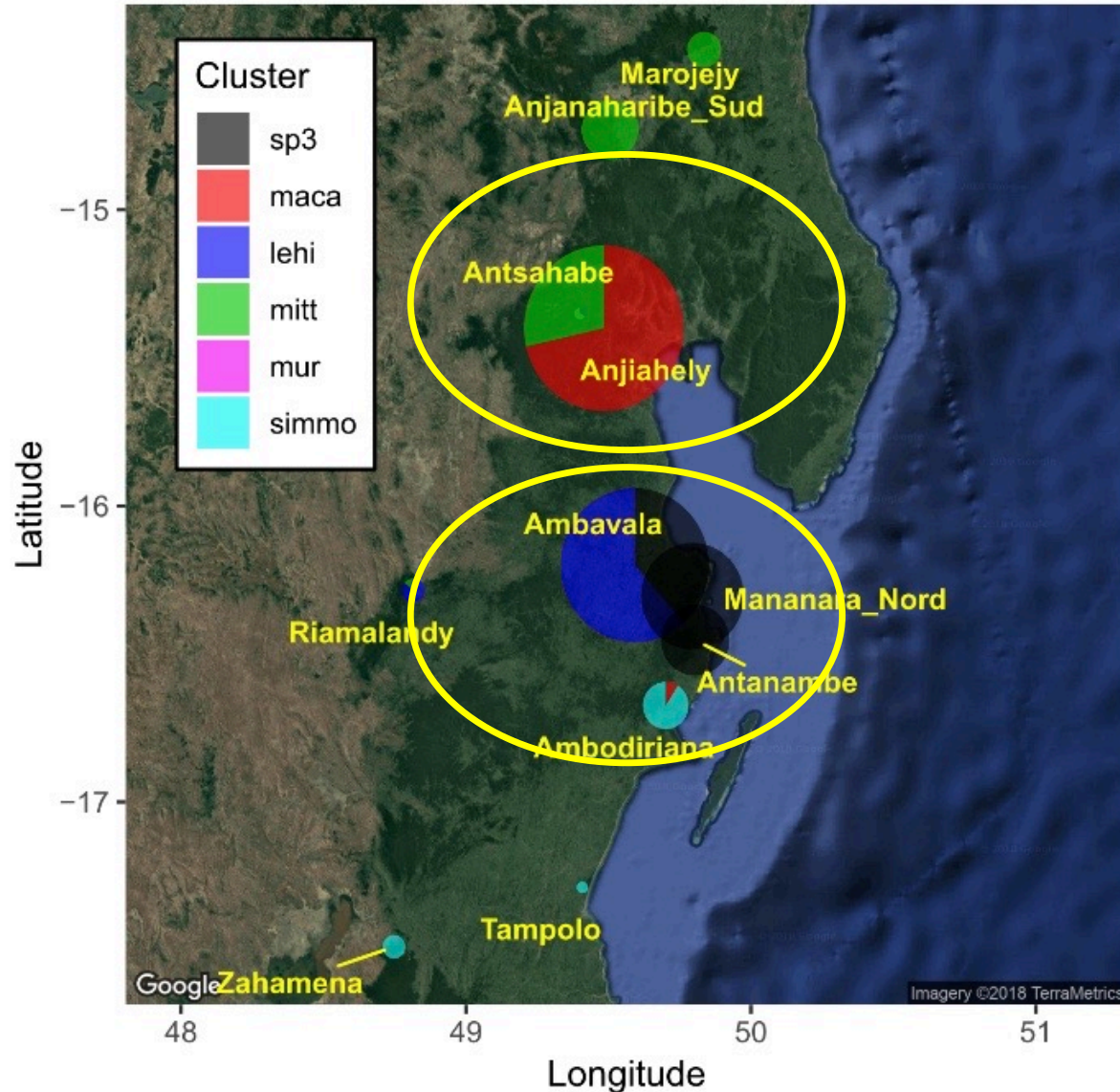

*M. mittermeieri*  
&  
*M. macarthurii*

*M. lehilahyisara*  
&  
*M. sp.nov3*

## Phylogenetic context of sympatric species pairs

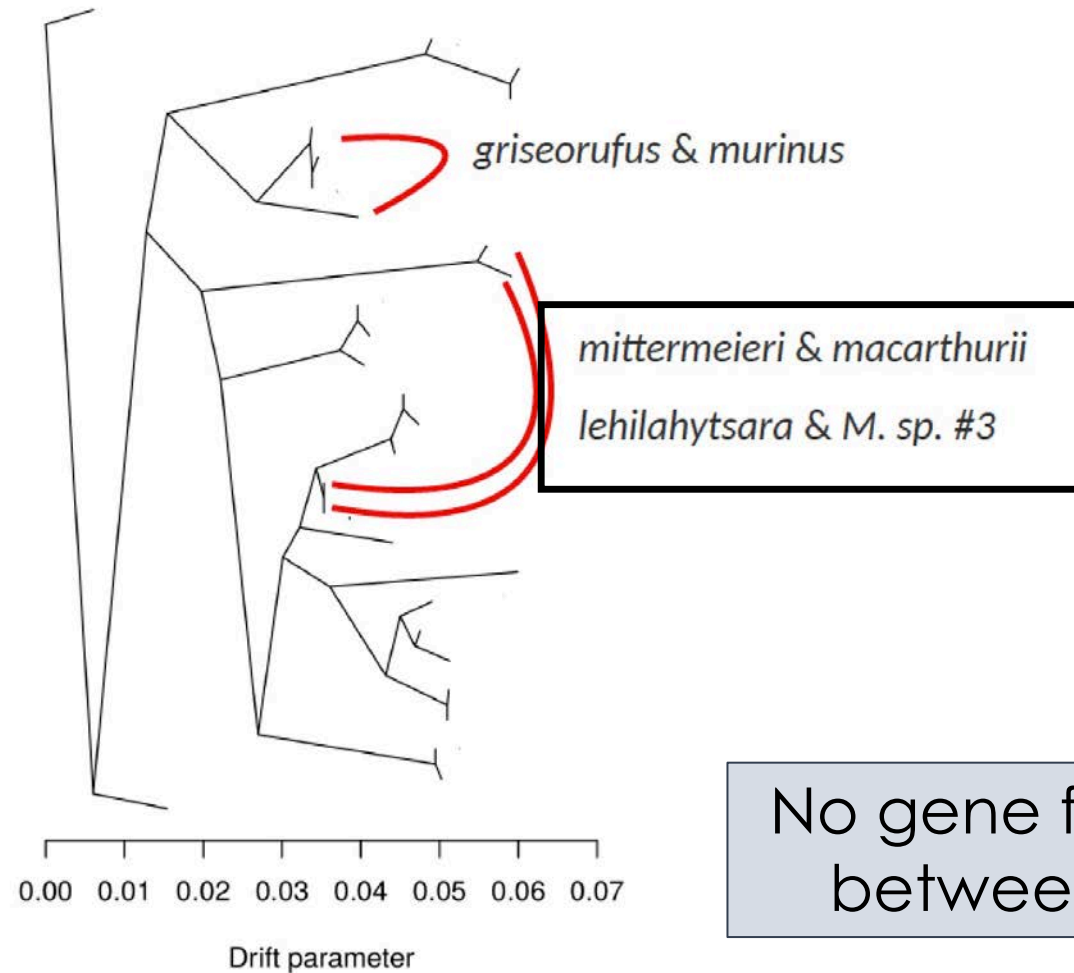

No gene flow detected  
between either pair

**GPhoCS *without* migration yields very different divergence time for species pair #2 versus *with* migration (~100 ka ago versus 400 ka ago)**

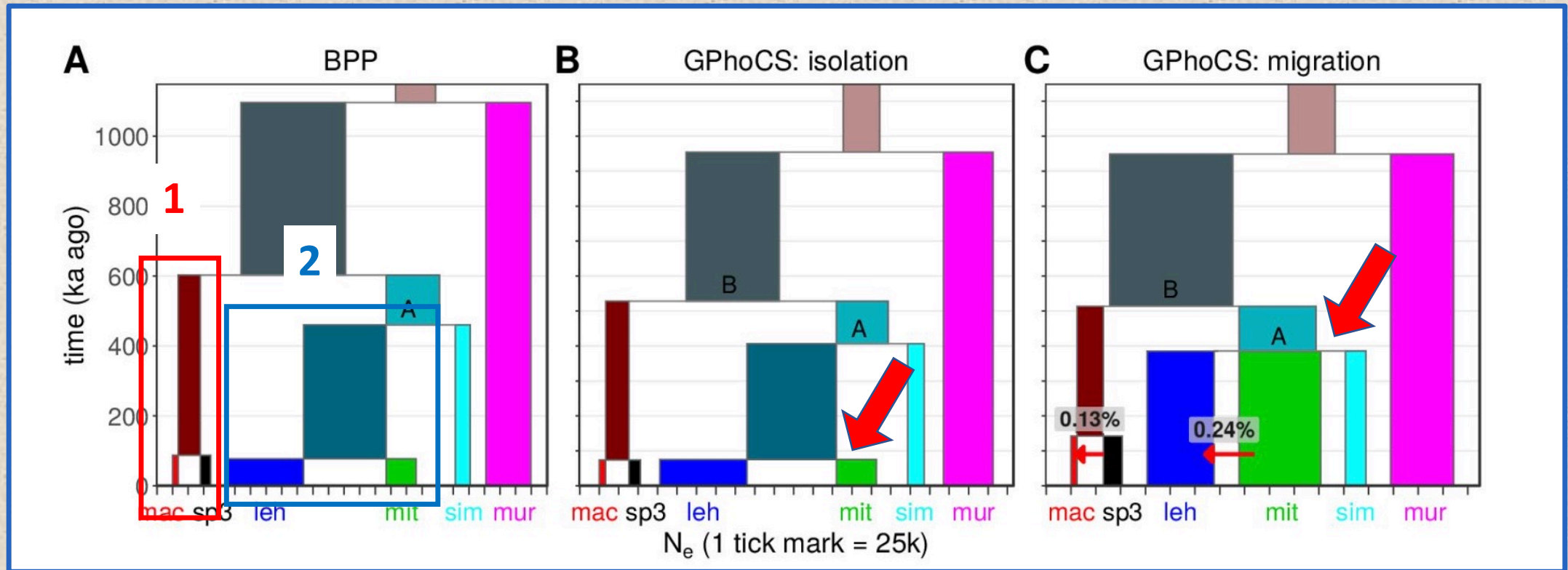

# PSMC analysis reveals that new species (*M. jonahi*) is in steep decline

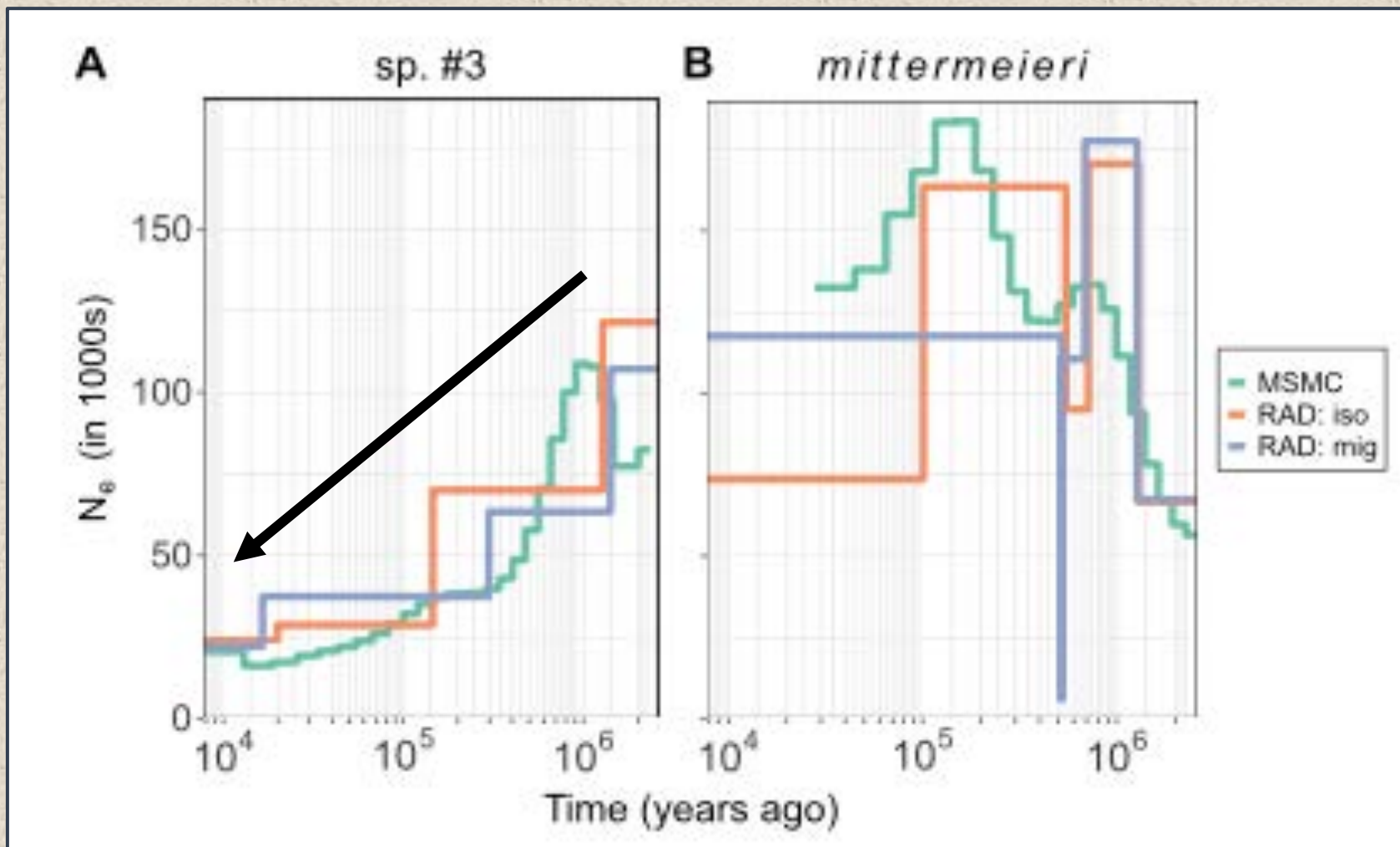





Received: 5 April 2020 | Revised: 3 June 2020 | Accepted: 9 July 2020  
DOI: 10.1002/ajp.23180

RESEARCH ARTICLE

### Ecology and morphology of mouse lemurs (*Microcebus* spp.) in a hotspot of microendemism in northeastern Madagascar, with the description of a new species

Dominik Schübler<sup>1</sup> | Marina B. Blanco<sup>2,3</sup> | Jordi Salmons<sup>4</sup> | Jelmer Poelstra<sup>3</sup>  
Jean B. Andriambelolon<sup>5</sup> | Alex Miller<sup>6</sup> | Blanchard Randrianambinina<sup>7,8</sup> |  
David W. Rasolofson<sup>7</sup> | Jasmin Mantilla-Contreras<sup>1</sup> | Lounès Chikhi<sup>4,6</sup> |  
Edward E. Louis Jr.<sup>9</sup> | Paul D. Yoder<sup>3</sup> | Ute Radespiel<sup>10</sup>

## Systematic Biology

ACCEPTED MANUSCRIPT

### Cryptic Patterns of Speciation in Cryptic Primates: Microendemic Mouse Lemurs and the Multispecies Coalescent

Jelmer Poelstra, Jordi Salmons, George P Tiley, Dominik Schübler, Marina B Blanco, Jean B Andriambelolon, Olivier Bouchez, C Ryan Campbell, Paul D Etter, Paul A Hohenlohe ... Show more

Systematic Biology, syaa053, <https://doi.org/10.1093/sysbio/syaa053>  
Published: 08 July 2020 Article history

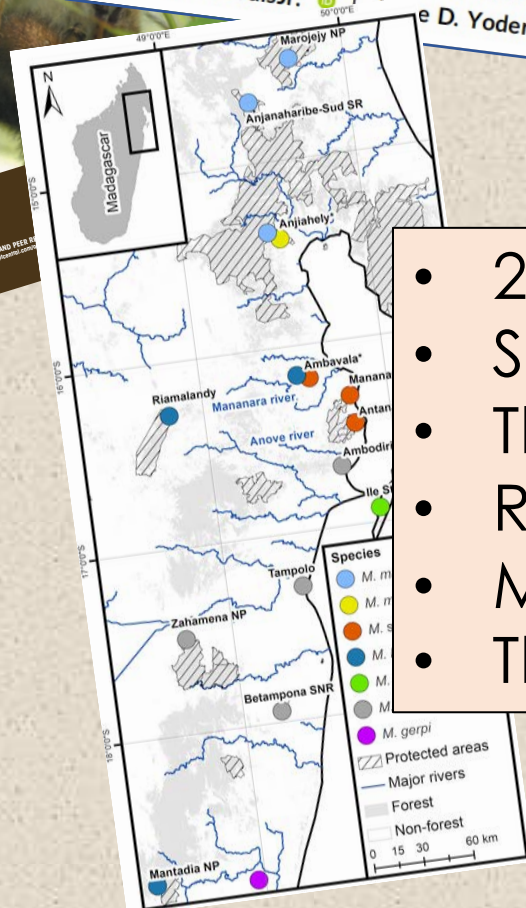

- 27 authors
- Six countries
- Three continents
- RADseq (120,000 loci per individual)
- Many years of field effort
- Thousands of hours of CPU time

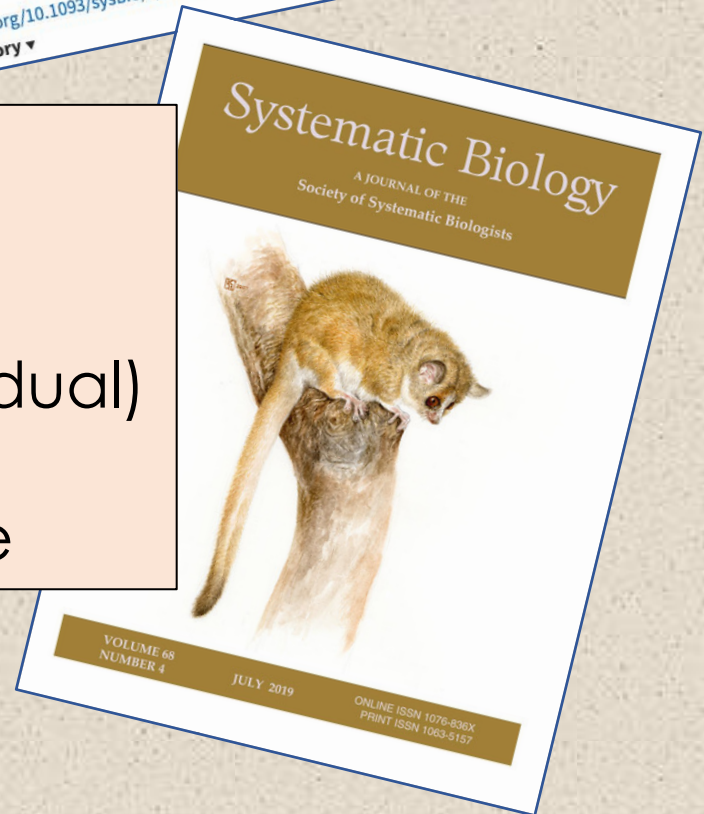

## Summary of Story 2:

- Have discovered a new microendemic species of acute conservation concern
- We discovered two areas of microendemism where two lineages co-occur without gene flow
- Divergence time estimates suggest that reproductive isolation (RI) can evolve rapidly ... < 700 kya in this case

# Story #3

## PROCEEDINGS B

royalsocietypublishing.org/journal/rspb

Research



**Cite this article:** Poelstra JW, Montero BK, Lüdemann J, Yang Z, Rakotondranary SJ, Hohenlohe P, Stetter N, Ganzhorn JU, Yoder AD. 2022 RADseq data reveal a lack of admixture in a mouse lemur contact zone contrary to previous microsatellite results. *Proc. R. Soc. B* **289**: 20220596.  
<https://doi.org/10.1098/rspb.2022.0596>

## RADseq data reveal a lack of admixture in a mouse lemur contact zone contrary to previous microsatellite results

Jelmer W. Poelstra<sup>1,2</sup>, B. Karina Montero<sup>3</sup>, Jan Lüdemann<sup>3</sup>, Ziheng Yang<sup>4</sup>, S. Jacques Rakotondranary<sup>3,5</sup>, Paul Hohenlohe<sup>6</sup>, Nadine Stetter<sup>3,7</sup>, Jörg U. Ganzhorn<sup>3,†</sup> and Anne D. Yoder<sup>1,†</sup>

<sup>1</sup>Department of Biology, Duke University, Durham, NC 27708, USA

<sup>2</sup>Molecular and Cellular Imaging Center, Ohio State University, Wooster, OH 44691, USA

<sup>3</sup>Institute of Zoology, Department of Animal Ecology and Conservation, Universität Hamburg, Hamburg, 20146, Germany

<sup>4</sup>Department of Genetics, Evolution and Environment, University College London, London, UK

<sup>5</sup>Anthropobiologie et Développement Durable, Faculté des Sciences, Université d'Antananarivo, PO Box 906, Antananarivo 101, Madagascar

<sup>6</sup>Institute for Bioinformatics and Evolutionary Studies, Department of Biological Sciences, University of Idaho, Moscow, ID 83844, USA

<sup>7</sup>Bernhard Nocht Institute for Tropical Medicine, 20359 Hamburg, Germany



Jelmer Poelstra

## Hybridization between mouse lemurs in an ecological transition zone in southern Madagascar

M. GLIGOR,\* J. U. GANZHORN,† D. RAKOTONDRAVONY,‡ O. R. RAMILJAONA,‡  
E. RAZAFIMAHATRATRA,† H. ZISCHLER\* and A. HAPKE\*

Gligor et al. 2009, Mol Ecol

## Hybridization of mouse lemurs: different patterns under different ecological conditions

Andreas Hapke<sup>1\*</sup>, Mark Gligor<sup>1,2</sup>, S Jacques Rakotonranary<sup>3</sup>, David Rosenkranz<sup>1</sup> and Oliver Zupke<sup>1,4</sup>

Hapke et al. 2011, BMC Ev Biol

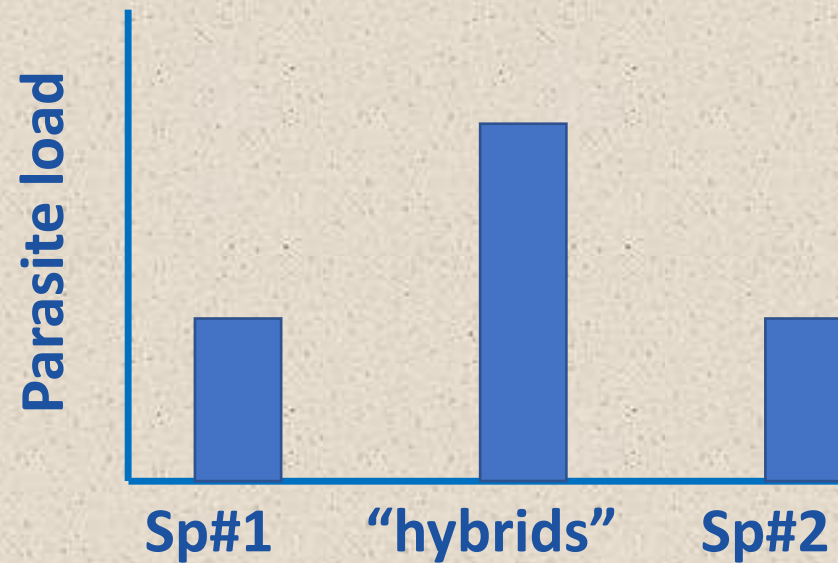

Jörg Ganzhorn



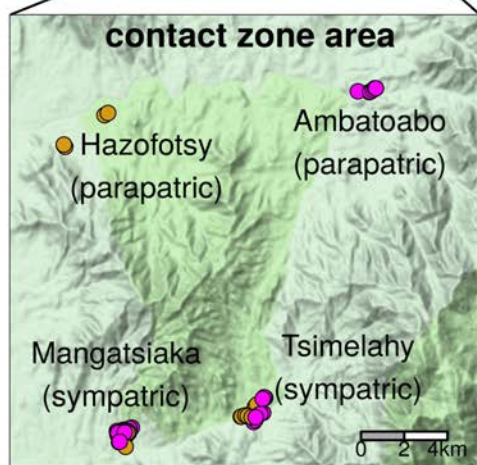
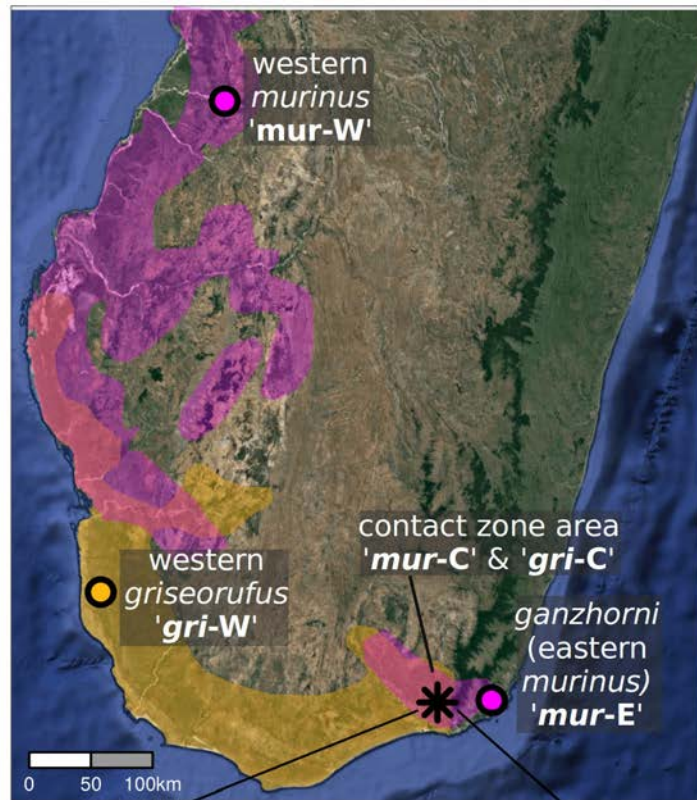

- 80 individuals from two contact zone sites
- 20 individuals from nearby micro-allopatric sites
- 38 individuals from distant allopatric sites
- 3 outgroup individuals (*M. rufus*)

## Site 1: syntopic overlap

## Site 2: “micro-allopatry”

**C** sympatric site 1: Mangatsiaka

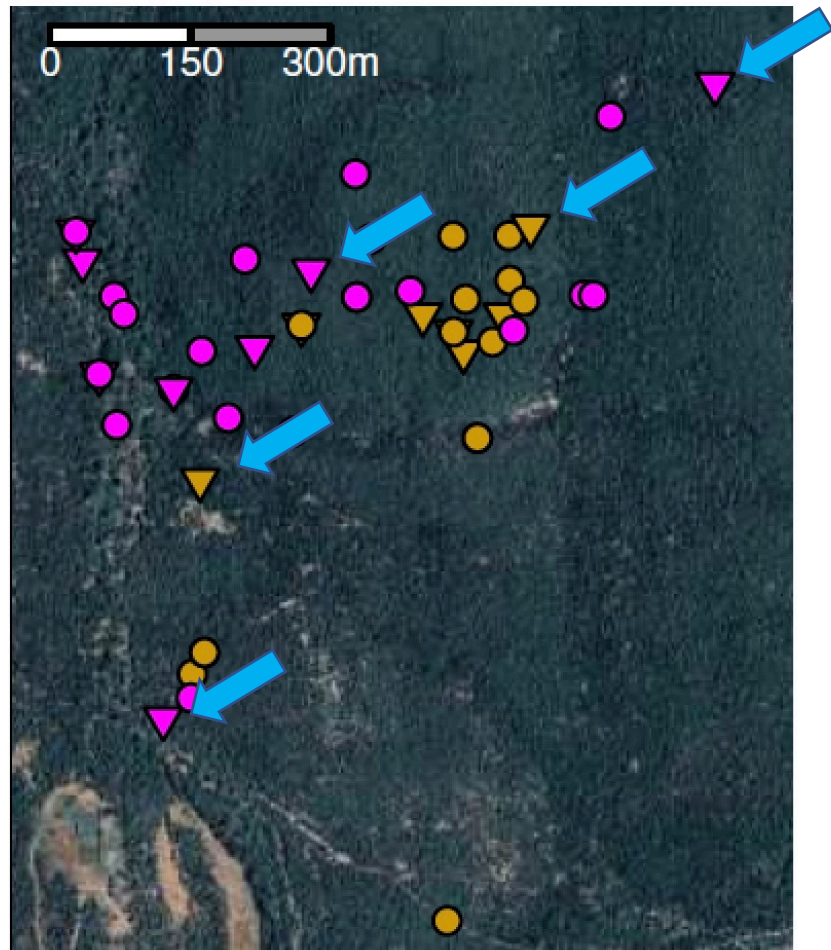

sympatric site 2: Tsimelahy

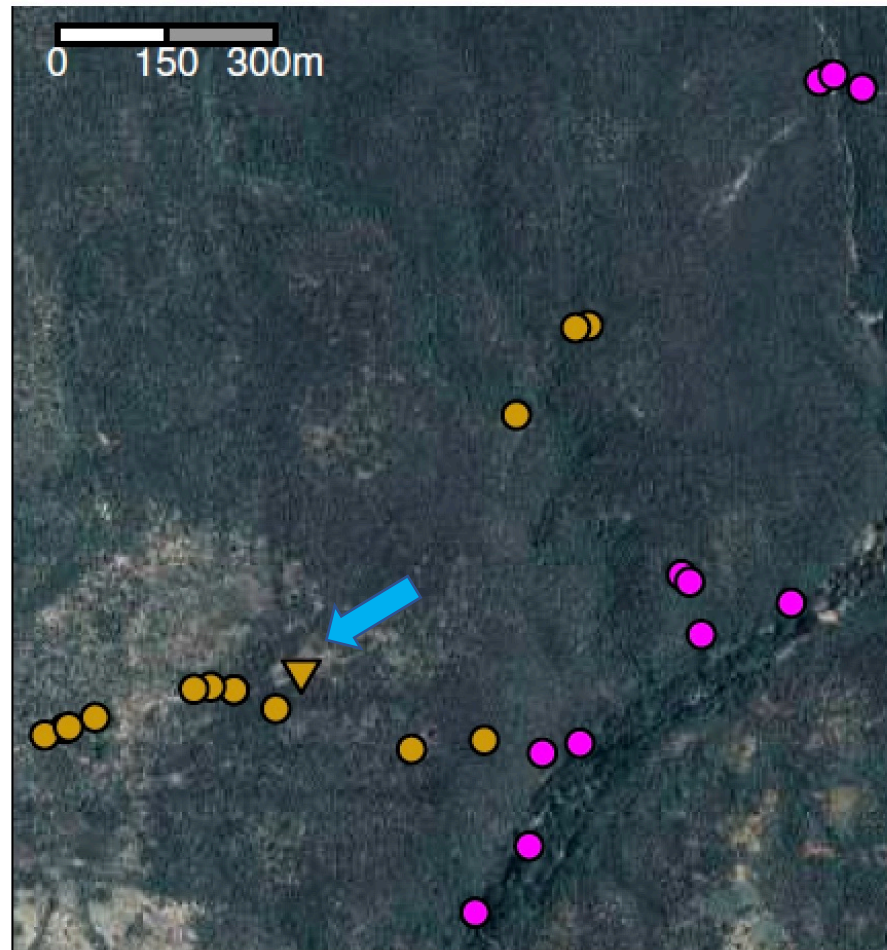

**microsat  
assignment:**  
▽ hybrid  
○ non-hybrid

**RADseq  
assignment:**  
● *griseorufus*  
● *murinus*

# Both ADMIXTURE and PCA indicate that putative hybrids are pure parental species

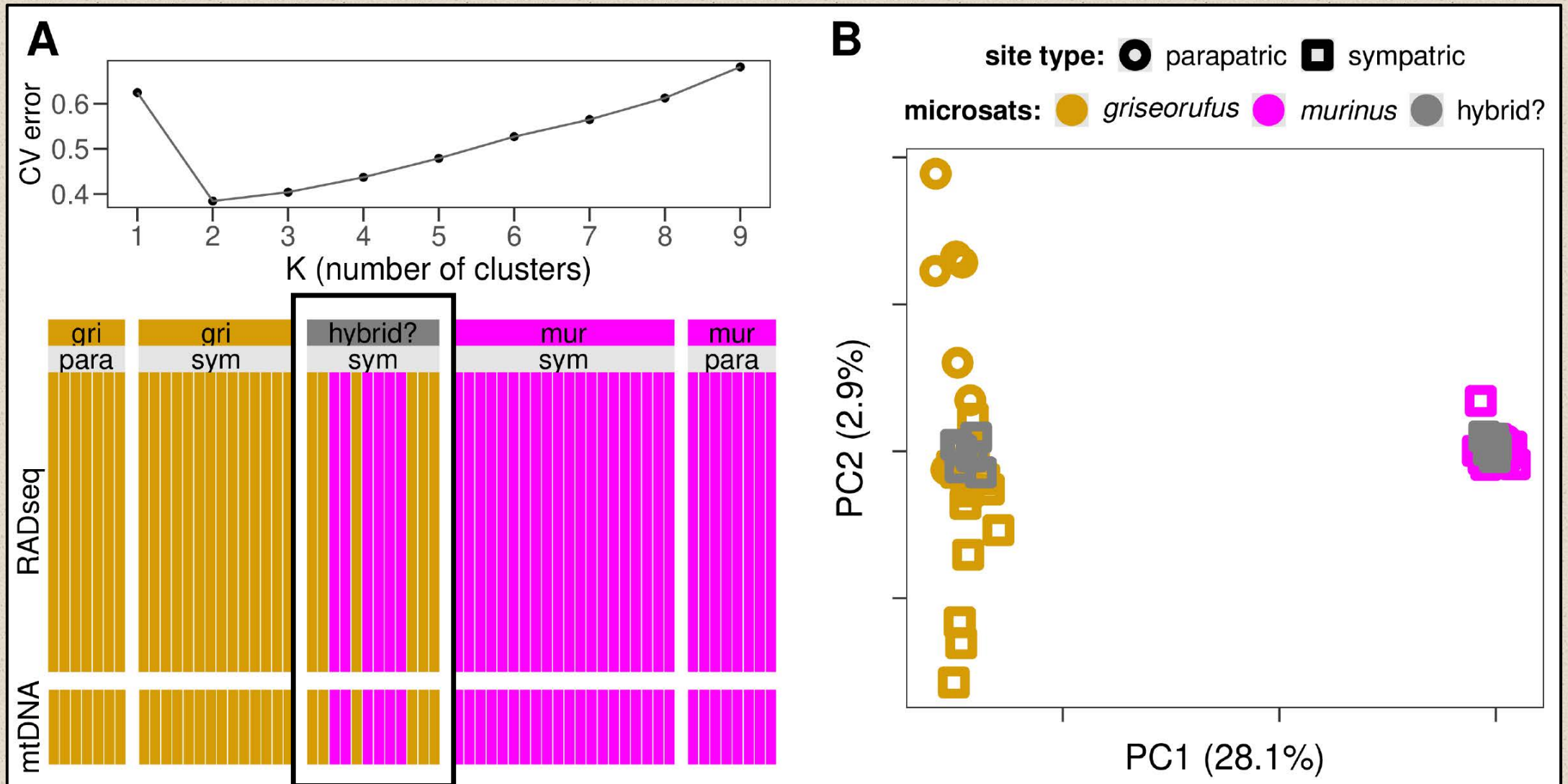



Slide courtesy of Jörg Ganzhorn



# GPhoCS (with migration)

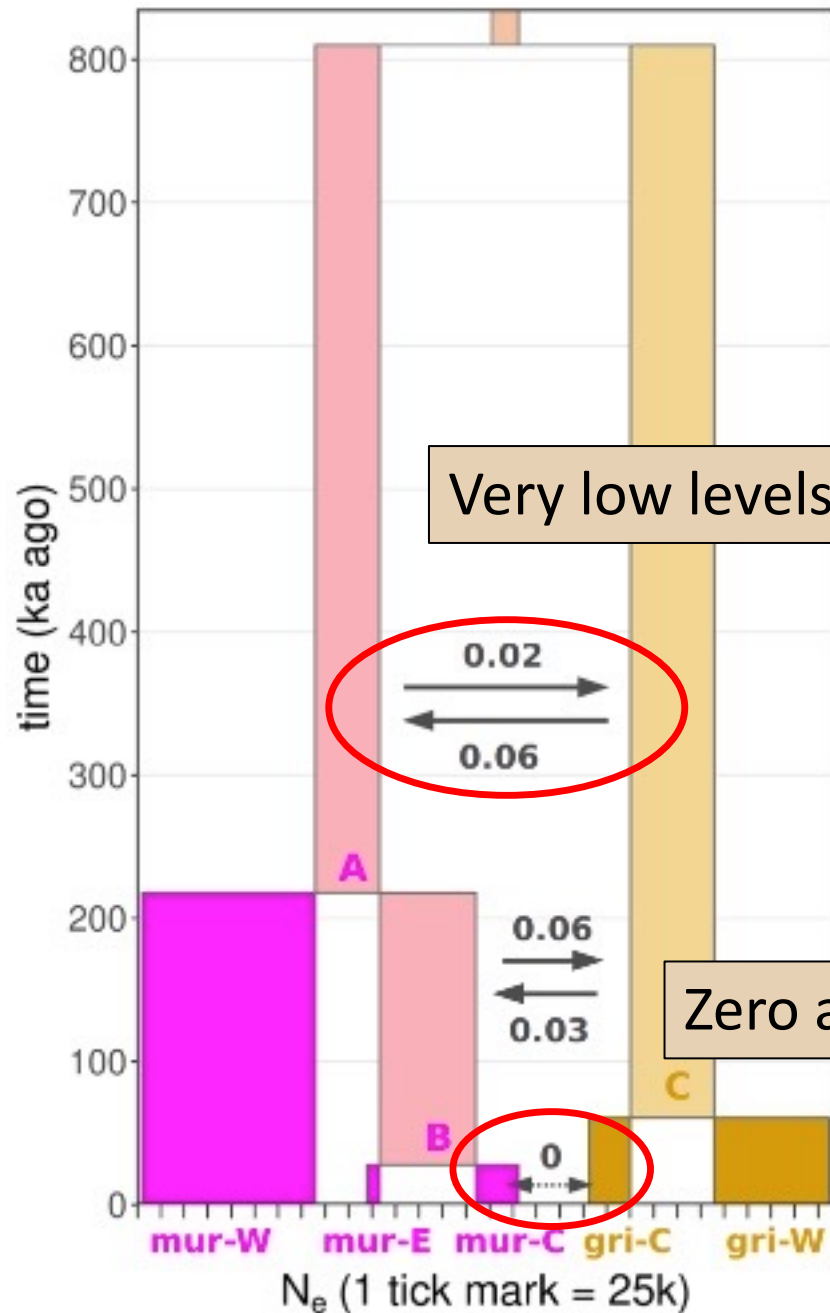

Very low levels of gene flow since initial divergence

Zero at present

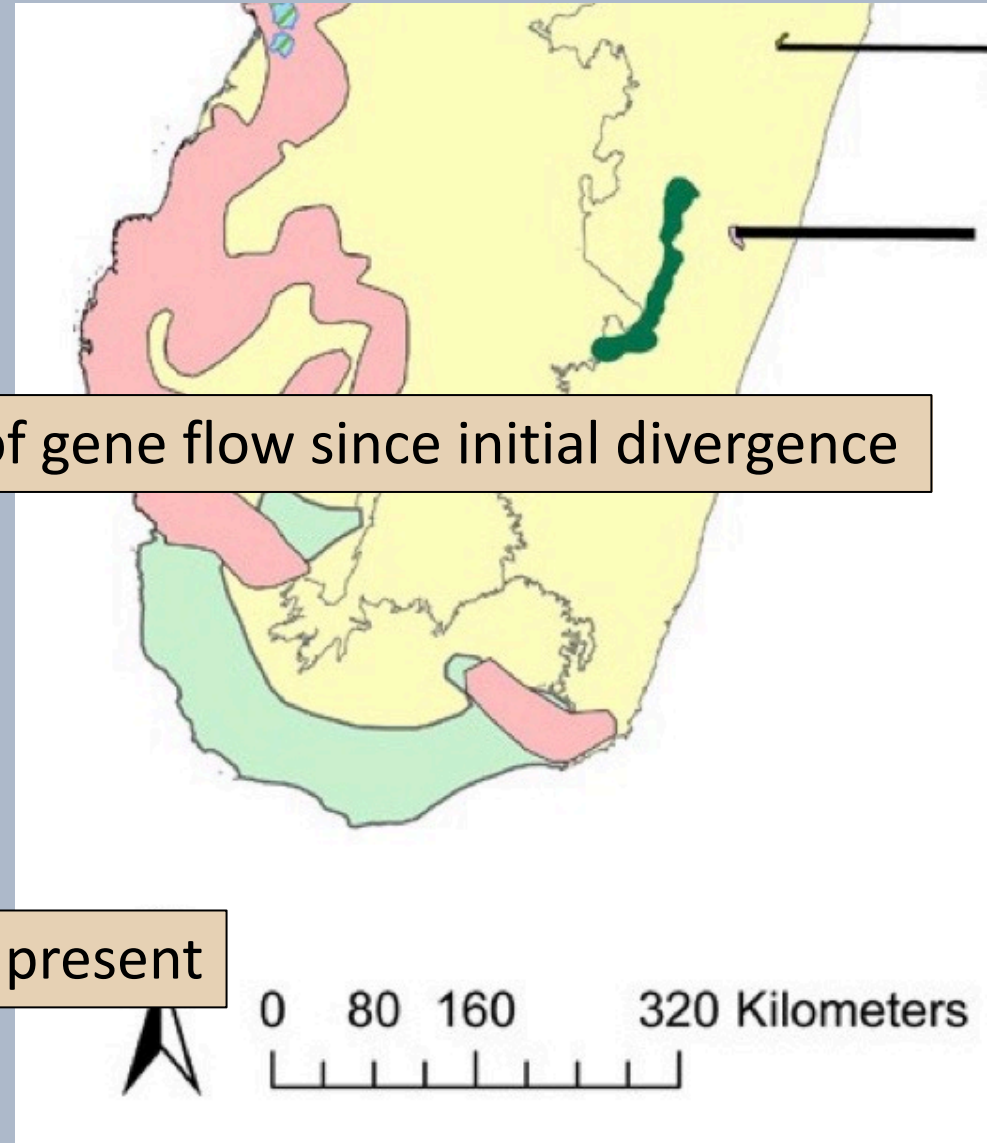

## Summary of Story 3:

- Microsatellite data can be misleading
- Genome-scale data and MSC analysis have provided new and contradictory insights
- Two species that diverged less than 1 mya ago appear to have achieved complete reproductive isolation (RI)
- We have no idea what are the mechanisms driving and maintaining RI

**Complete RI in < 800,000 ybp!**

**How?**

**Why?**

**What?**

# **Future Directions**

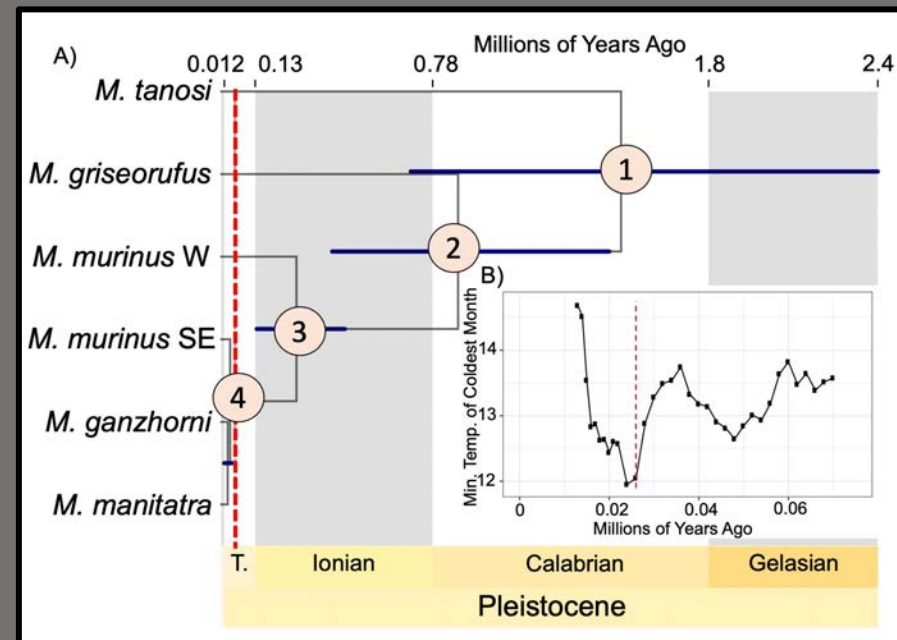
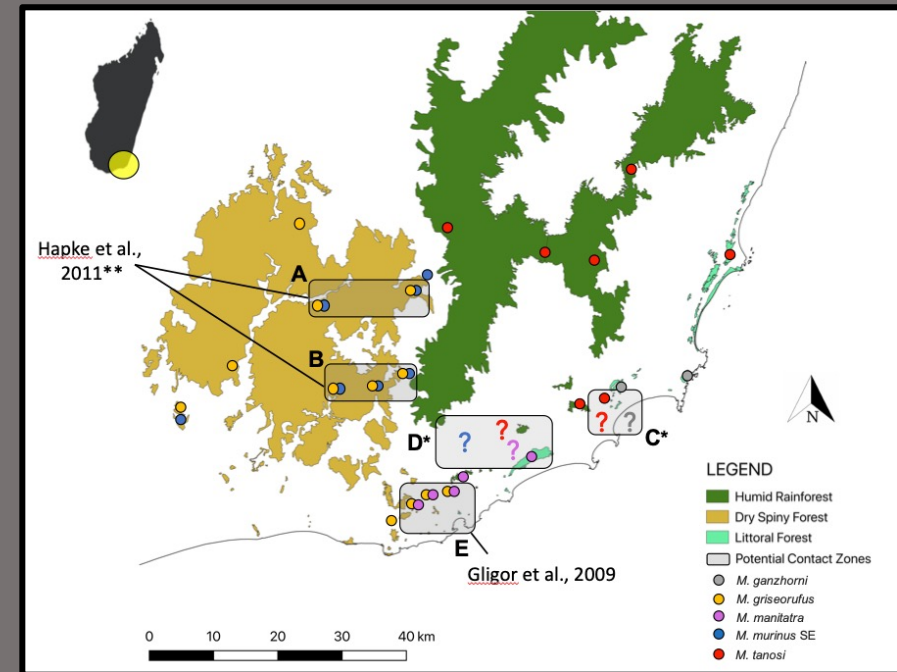
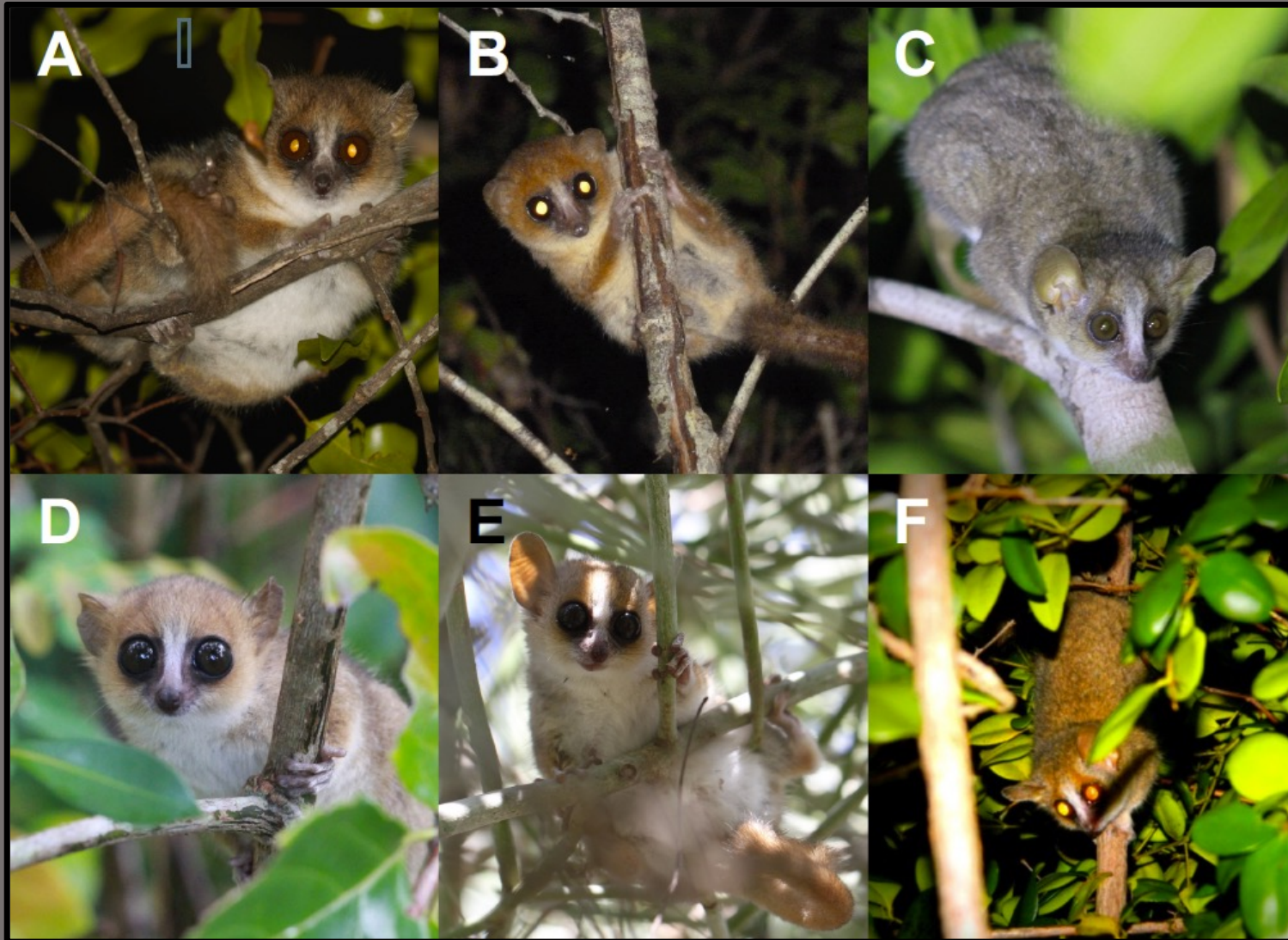



# Speciation Continuum

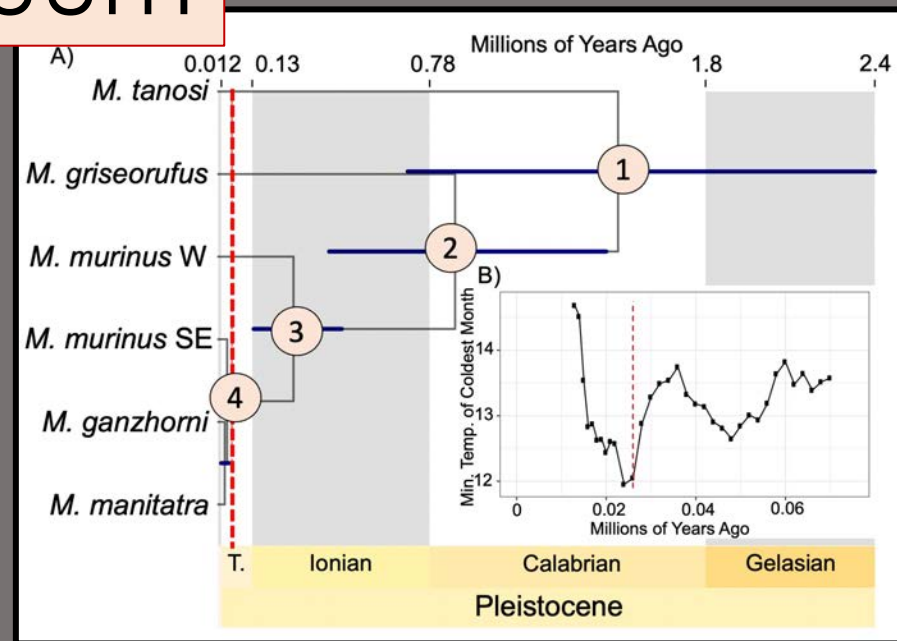
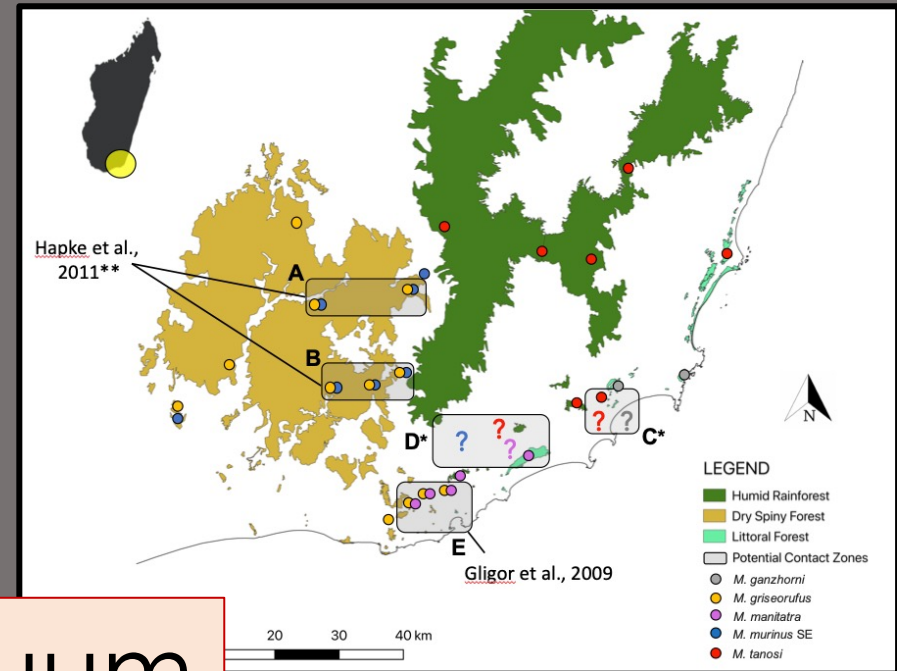

# Ancestral Lineage

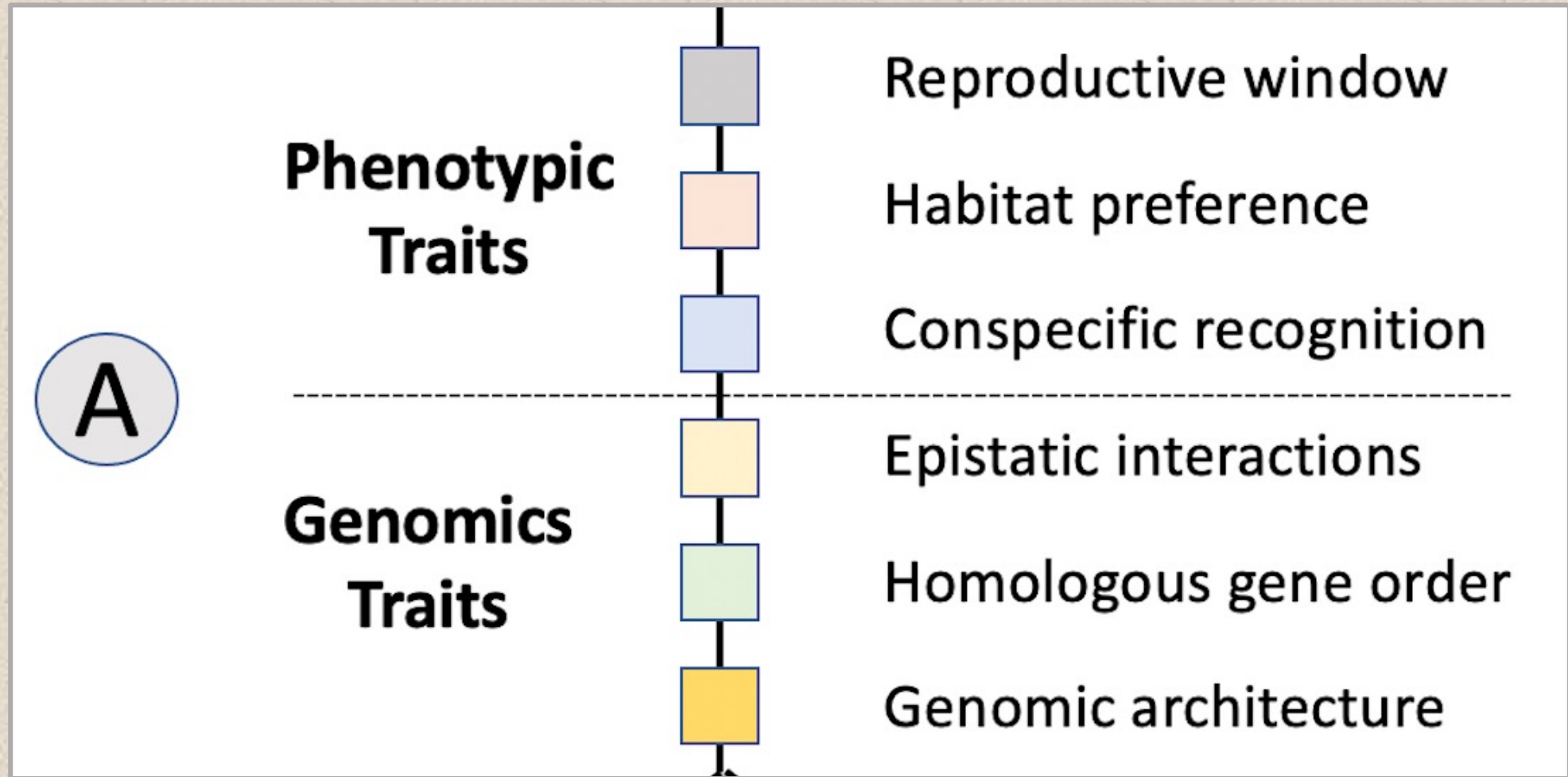

B

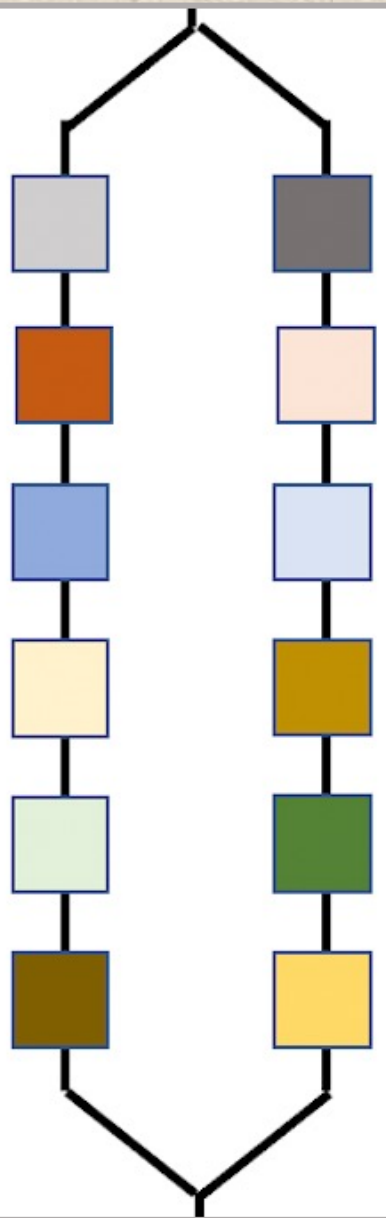

**Geographic  
Separation**



# Secondary Contact

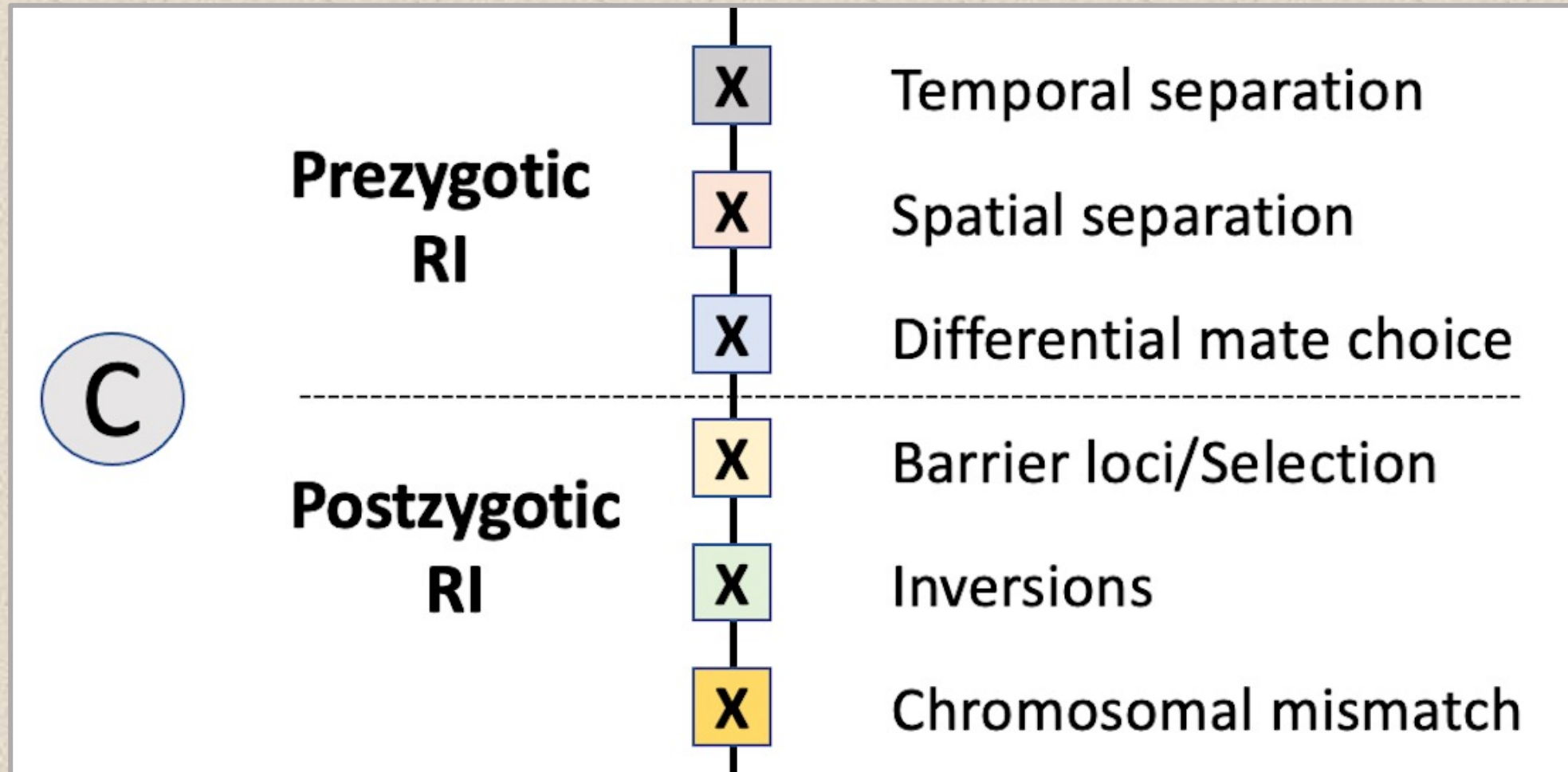

# Auditory Communication

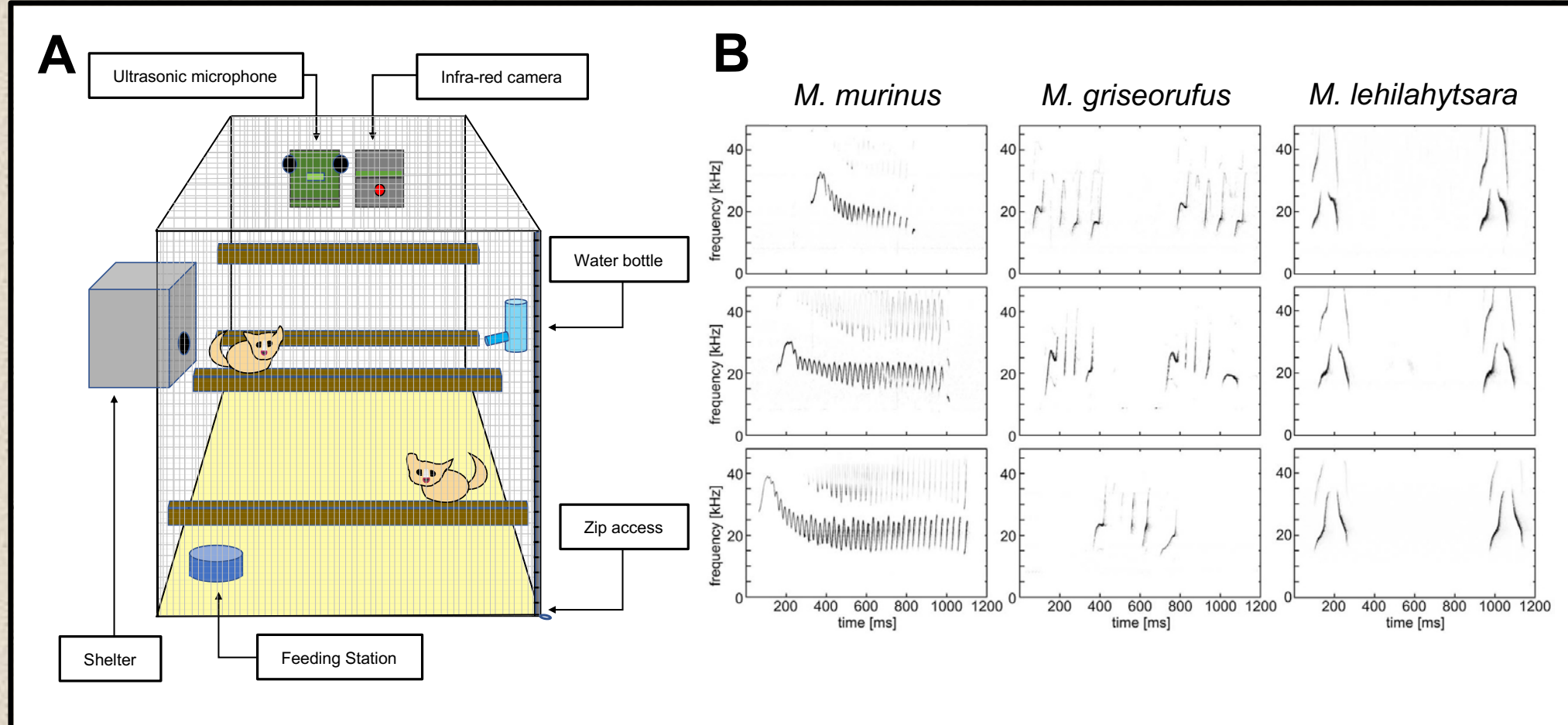

# Olfactory Communication

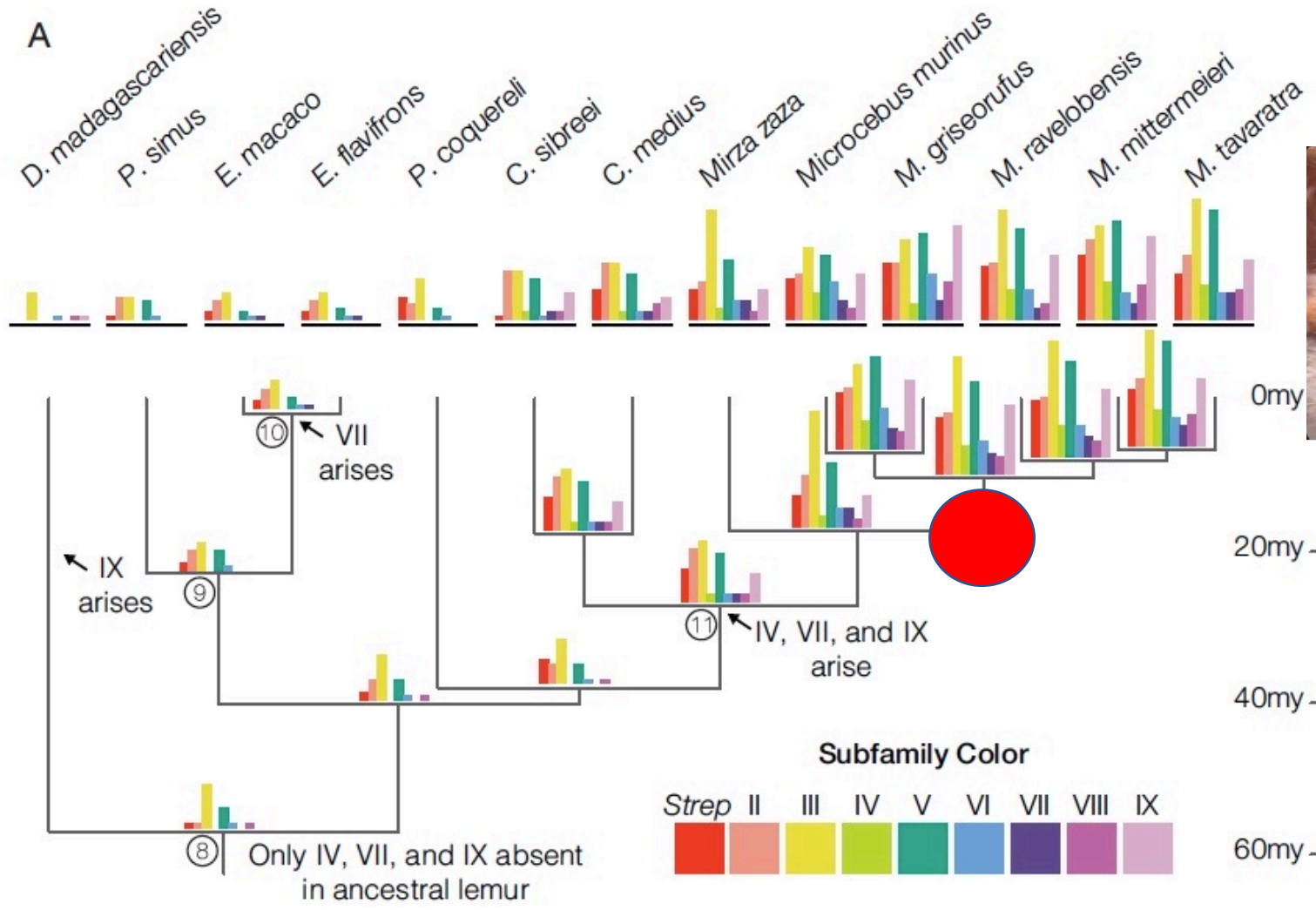

GPCR  
Pheromone  
receptors





# Movement Ecology



**Lydia Greene**  
(sensory biology;  
outreach)



**Paschalia Kapli**  
(computational  
genomics)



**Carolina Segami**  
(speciation  
genomics)



**Sam Hyde Roberts**  
(field methods;  
conservation)



me

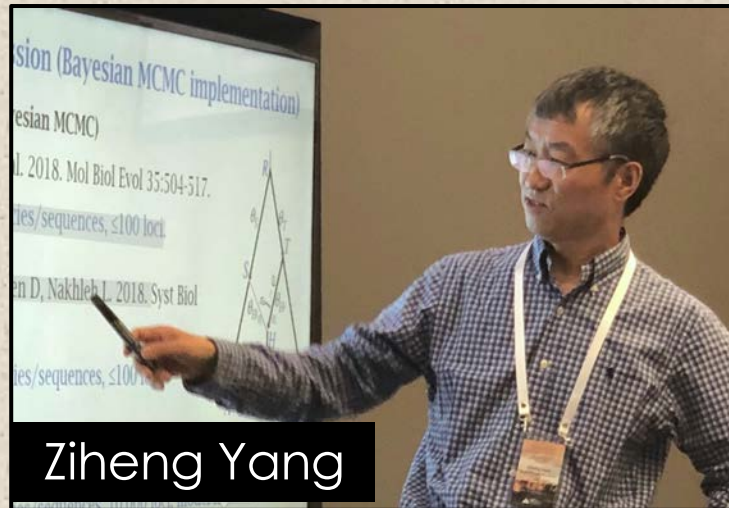

**Ziheng Yang**



**Marina  
Blanco**





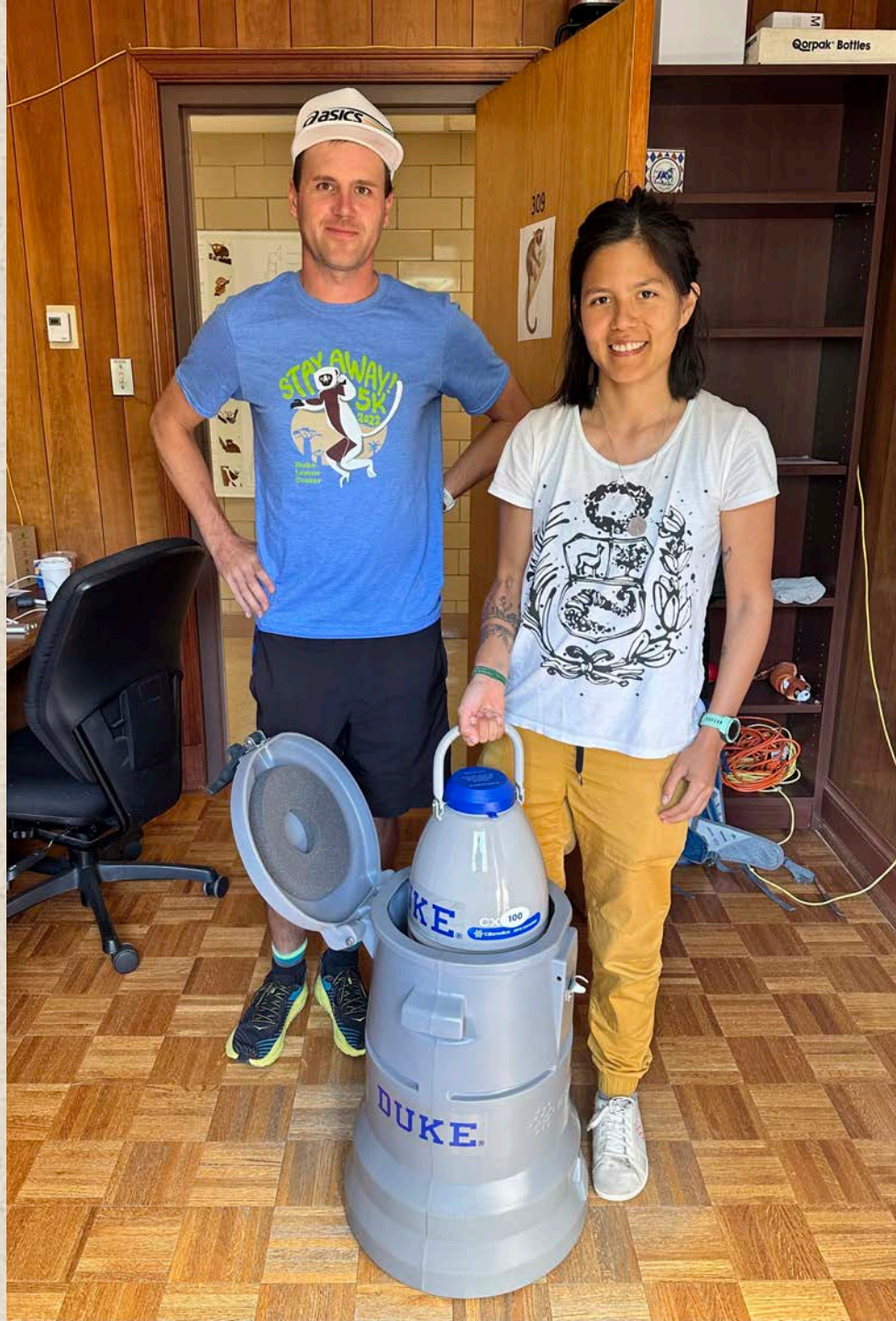







Conservation Genetics  
<https://doi.org/10.1007/s10592-020-01296-0>

PERSPECTIVE



## Next-generation technologies applied to age-old challenges in Madagascar

Marina B. Blanco<sup>1,2</sup> · Lydia K. Greene<sup>1,2,3</sup> · Fidisoa Rasambainarivo<sup>4</sup> · Elizabeth Toomey<sup>4</sup> · Rachel C. Williams<sup>1,2</sup> · Lanto Andrianandrasana<sup>5</sup> · Peter A. Larsen<sup>2,6</sup> · Anne D. Yoder<sup>2</sup>

Received: 27 April 2020 / Accepted: 20 July 2020  
© The Author(s) 2020





Achille Raselimana  
Fidisoa Rasambainarivo



Marina Blanco



Lydia Greene





LAB ANALYSES



RESEARCH



VET SERVICES



ZARA-SCI

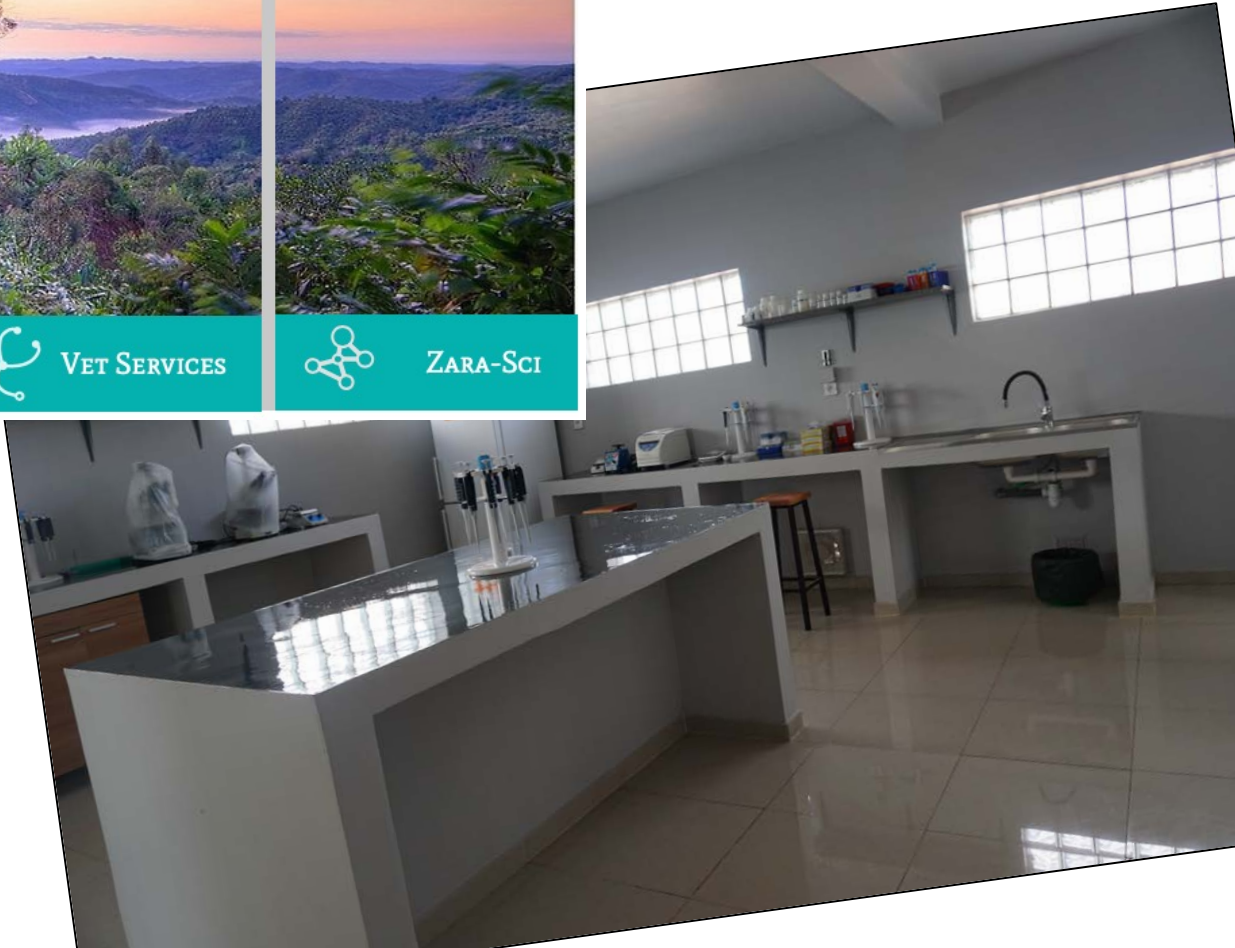





Hi Anne,  
... We are here now and they are so interesting!! Much more difficult to catch, **very aggressive and feisty**. They have huge ears in proportion to their body and look like an intermediate from grey and brown. This ecosystem is fascinating. Anyway I hope we finish fast here so I can have a sit and hopefully get good internet to look at those sequences. It would be nice to create an export link to send to Ziheng.  
Cheers  
Caro

**Yesterday!!!**